

INTERNATIONAL MARITIME
ORGANIZATION



A 18/Res.744
23 November 1993
Original: ENGLISH

ASSEMBLY - 18th session
Agenda item 13

RESOLUTION A.744(18)
adopted on 4 November 1993

GUIDELINES ON THE ENHANCED PROGRAMME OF INSPECTIONS
DURING SURVEYS OF BULK CARRIERS AND OIL TANKERS

THE ASSEMBLY,

RECALLING Article 15(j) of the Convention on the International Maritime Organization concerning the functions of the Assembly in relation to regulations and guidelines concerning maritime safety and the prevention and control of marine pollution from ships,

RECALLING ALSO resolution A.713(17) on Safety of ships carrying solid bulk cargoes, by which it specified interim measures to be taken to improve the safety of ships carrying solid bulk cargoes,

RECALLING FURTHER its request to the Maritime Safety Committee to carry out its work on the safety of ships carrying solid bulk cargoes with high priority and to develop, inter alia, requirements for the enhanced programme of survey of such ships,

RECALLING ALSO that by resolution MEPC.52(32) the Marine Environment Protection Committee adopted amendments to the Annex to the Protocol of 1978 relating to the International Convention for the Prevention of Pollution from Ships, 1973 regarding new regulations 13F and 13G and related amendments to Annex I of MARPOL 73/78 to improve the requirements for the design and construction of oil tankers to prevent oil pollution in the event of collision or stranding,

NOTING that in accordance with the above regulation 13G, crude oil tankers of 20,000 tons deadweight and above and product carriers of 30,000 tons deadweight and above shall be subject to the enhanced programme of inspections, the scope and frequency of which shall at least comply with the guidelines developed by the Organization,

RECOGNIZING the need to also provide the guidelines on the enhanced programme of inspections for all oil tankers in order to further promote safety and marine pollution prevention,

HAVING CONSIDERED the recommendations made by the Maritime Safety Committee at its sixty-second session and the Marine Environment Protection Committee at its thirty-fourth session,

W/0372a

A 18/Res.744

- 2 -

1. ADOPTS:

- .1 the Guidelines on the Enhanced Programme of Inspections During Surveys of Bulk Carriers, set out in Annex A to the present resolution, and
 - .2 the Guidelines on the Enhanced Programme of Inspections During Surveys of Oil Tankers, set out in Annex B to the present resolution;
2. INVITES Governments to apply the Guidelines as soon as possible to all bulk carriers and oil tankers respectively;
3. REQUESTS the Maritime Safety Committee and the Marine Environment Protection Committee to keep the Guidelines under review and update them as necessary, in the light of experience gained in their application.

ANNEX A

GUIDELINES ON THE ENHANCED PROGRAMME OF INSPECTIONS DURING
SURVEYS OF BULK CARRIERS

Contents

- 1 GENERAL
 - 1.1 Application
 - 1.2 Definitions
 - 1.3 Scope of surveys
- 2 ENHANCED SURVEY CARRIED OUT DURING PERIODICAL SURVEY
 - 2.1 General
 - 2.2 Dry-dock survey
 - 2.3 Tank corrosion prevention system
 - 2.4 Hatch covers and coamings
 - 2.5 Extent of overall and close-up surveys
 - 2.6 Extent of thickness measurements
 - 2.7 Extent of tank pressure testing
- 3 ENHANCED SURVEY CARRIED OUT DURING ANNUAL SURVEY
 - 3.1 General
 - 3.2 Examination of the hull
 - 3.3 Examination of hatch covers and coamings
 - 3.4 Examination of cargo holds
 - 3.5 Examination of ballast tanks
- 4 INTERMEDIATE ENHANCED SURVEY
 - 4.1 General
 - 4.2 Ballast tanks
 - 4.3 Cargo holds
 - 4.4 Extent of thickness measurements
- 5 PREPARATIONS FOR SURVEY
 - 5.1 Planning
 - 5.2 Conditions for survey
 - 5.3 Access to structures
 - 5.4 Equipment for survey
 - 5.5 Survey at sea or at anchorage
- 6 DOCUMENTATION ON BOARD
 - 6.1 General
 - 6.2 Survey report file
 - 6.3 Supporting documents
 - 6.4 Review of documentation on board

7 PROCEDURES FOR THICKNESS MEASUREMENTS

7.1 General

7.2 Certification of thickness measurement company

7.3 Reporting

8 REPORTING AND EVALUATION OF SURVEY

8.1 Evaluation of survey report

8.2 Reporting

Annex 1 Requirements for close-up survey at periodical surveys

Annex 2 Requirements for thickness measurements at periodical surveys

Annex 3 Owner's inspection report

Annex 4 Principles for planning document

Annex 5 Procedures for certification of a company engaged in thickness measurements of hull structures

Annex 6 Reporting principles

Annex 7 Condition evaluation report

Annex 8 Recommended procedures for thickness measurements

Appendix 1 General particulars

Appendix 2 Reports on thickness measurement

Appendix 3 Guidance on thickness measurement

GUIDELINES ON THE ENHANCED PROGRAMME OF INSPECTIONS DURING SURVEYS OF BULK CARRIERS

1 GENERAL

1.1 Application*

1.1.1 The Guidelines should apply to surveys of hull structure and piping systems in way of cargo holds, cofferdams, pipe tunnels, void spaces within the cargo length area and all ballast tanks. The surveys should be carried out during the surveys prescribed by the 1974 SOLAS Convention, as amended.

1.1.2 The Guidelines contain the extent of examination, thickness measurements and tank testing. The survey should be extended when substantial corrosion and/or structural defects are found and include additional close-up survey when necessary.

1.2 Definitions

1.2.1 Bulk carrier is a ship which is constructed generally with single deck, top-side tanks and hopper side tanks in cargo spaces, and is intended primarily to carry dry cargo in bulk and includes such types as ore carriers and combination carriers**.

1.2.2 Ballast tank is a tank which is used for water ballast and includes side ballast tanks, ballast double bottom spaces, top-side tanks, hopper side tanks and peak tanks.

1.2.3 Spaces are separate compartments including holds and tanks.

1.2.4 Overall survey is a survey intended to report on the overall condition of the hull structure and determine the extent of additional close-up surveys.

1.2.5 Close-up survey is a survey where the details of structural components are within the close visual inspection range of the surveyor, i.e. preferably within reach of hand.

1.2.6 Transverse section includes all longitudinal members such as plating, longitudinals and girders at the deck, side and bottom, inner bottom and hopper side plating, longitudinal bulkheads, and bottom plating in top wing tanks.

* The intention of these Guidelines is to ensure that an appropriate level of review of plans and documents is conducted and consistency in application is attained. Such evaluation of survey reports, survey programmes, planning documents, etc., should be carried out at the managerial level of the Administration or organization recognized by the Administration.

** For combination carriers additional requirements are specified in the Guidelines on the Enhanced Programme of Inspections During Surveys for Oil Tankers set out in Annex B to the present resolution.

1.2.7 Representative spaces are those which are expected to reflect the condition of other spaces of similar type and service and with similar corrosion prevention systems. When selecting representative spaces account should be taken of the service and repair history on board and identifiable critical and/or suspect areas.

1.2.8 Suspect areas are locations showing substantial corrosion and/or are considered by the surveyor to be prone to rapid wastage.

1.2.9 Substantial corrosion is an extent of corrosion such that assessment of corrosion pattern indicates a wastage in excess of 75% of allowable margins, but within acceptable limits.

1.2.10 Corrosion prevention system is normally considered either:

- .1 a full hard coating supplemented by anodes;
- .2 a full hard coating.

Other coating systems (e.g. soft coating) may be considered acceptable as alternatives provided that they are applied and maintained in compliance with the manufacturers specification.

1.2.11 Coating condition is defined as follows:

GOOD	condition with only minor spot rusting;
FAIR	condition with local breakdown of coating at edges of stiffeners and weld connections and/or light rusting over 20% or more of areas under consideration, but less than as defined for POOR condition;
POOR	condition with general breakdown of coating over 20% or more of areas or hard scale at 10% or more of areas under consideration.

1.2.12 Critical structural areas are locations which have been identified from calculations to require monitoring or from the service history of the subject ship or from similar or sister ships to be sensitive to cracking, buckling or corrosion which would impair the structural integrity of the ship.

1.2.13 Cargo length area is that part of the ship which includes all cargo holds and adjacent areas including fuel tanks, cofferdams, ballast tanks and void spaces.

1.2.14 Intermediate enhanced survey is an enhanced survey carried out either at the second or third annual survey or between these surveys.

1.3 Scope of surveys

1.3.1 Prior to inspection the surveyor should examine the completeness of documentation on board, and its contents as a basis for the survey.

1.3.2 When a survey results in the identification of significant corrosion or of significant structural defects which, in the opinion of the surveyor, will impair the structural integrity of the ship, then remedial action, in consultation with the Administration should be agreed and implemented before the ship continues in service.

2 ENHANCED SURVEY CARRIED OUT DURING PERIODICAL SURVEY

2.1 General

2.1.1 The enhanced survey may be commenced at the fourth annual survey and be progressed during the succeeding year with a view to completion by the fifth anniversary date.

2.1.2 As part of the preparation for the enhanced survey, the thickness measurement and survey programme should be dealt with, in advance of the enhanced survey. The thickness measurement should not be held before the fourth annual survey.

2.1.3 The survey should include, in addition to the requirements of the annual survey, examination, tests and checks of sufficient extent to ensure that the hull and related piping is in a satisfactory condition and is fit for its intended purpose for the new period of validity of the Cargo Ship Safety Construction Certificate, subject to proper maintenance and operation and to periodical surveys being carried out.

2.1.4 All cargo holds, ballast tanks, pipe tunnels, cofferdams and void spaces bounding cargo holds, decks and outer hull should be examined, and this examination should be supplemented by thickness measurement and testing as deemed necessary, to ensure that the structural integrity remains effective. The examination should be sufficient to discover substantial corrosion, significant deformation, fractures, damages or other structural deterioration.

2.1.5 All piping systems within the above spaces should be examined and operationally tested under working conditions to ensure that the condition remains satisfactory.

2.1.6 The survey extent of combined ballast/cargo holds should be evaluated based on the records of ballast history and extent of the corrosion prevention system provided.

2.1.7 The survey extent of ballast tanks converted to void spaces should be specially considered in relation to the requirements for ballast tanks.

2.2 Dry-dock survey

2.2.1 A survey in dry-dock should be a part of the enhanced survey during periodical survey. There should be a minimum of two inspections of the outside of the ship's bottom during the 5-year period of the certificate. In all cases, the maximum interval between bottom inspections should not exceed 36 months.

2.2.2 Alternate inspections of the ship's bottom not conducted in conjunction with the enhanced survey during periodical survey may be carried out with the ship afloat. Special consideration should be given to ships of 15 years of age or over before being permitted to have such inspections. Inspections of the ship afloat should only be carried out when the conditions are satisfactory and the proper equipment and suitably qualified staff are available.

2.2.3 If a survey in dry-dock is not completed in conjunction with the enhanced survey during periodical survey or if the 36 month maximum interval referred to in 2.2.1 is not complied with, the Cargo Ship Safety Construction Certificate should cease to be valid until a survey in dry-dock is completed.

2.2.4 However, in order to allow time for transition to the enhanced inspection system, until 6 July 1997, the Administration with a survey cycle of 4 years or less may carry out dry-dock surveys separately from the enhanced inspections during periodical survey. For ships to which this applies, the enhanced inspections during periodical survey should be conducted at facilities which possess the capabilities necessary to properly conduct the examinations and testing required, and all other requirements of the enhanced inspection guidelines should be met.

2.3 Tank corrosion prevention system

2.3.1 Where provided, the condition of the corrosion prevention system of ballast tanks should be examined. For ballast tanks, excluding double bottom tanks, where a coating is found in POOR condition as defined in 1.2.11, and it is not renewed, or where a coating has not been applied, the tanks in question should be examined at annual intervals. When such breakdown of coating is found in ballast double bottom tanks, or where a coating has not been applied the tanks in question may be examined at annual intervals. Thickness measurement should be carried out as considered necessary by the surveyor.

2.4 Hatch covers and coamings

2.4.1 A thorough inspection of the items listed in 3.3 should be carried out.

2.4.2 Random checking of the satisfactory operation of mechanically operated hatch covers should be made, including:

- .1 stowage and securing in open condition;
- .2 proper fit and efficiency of sealing in closed condition;
- .3 operational testing of hydraulic and power components, wires, chains, and link drives;

2.4.3 The effectiveness of sealing arrangements of all hatch covers by hose testing or equivalent should be checked.

2.4.4 Thickness measurement of the hatch cover and coaming plating and stiffeners should be carried out as given in annex 2.

2.5 Extent of overall and close-up surveys

2.5.1 An overall survey of all spaces excluding fuel oil tanks should be carried out at the periodical survey. Fuel oil tanks in way of cargo holds should be sufficiently examined to ensure that their condition is satisfactory.

2.5.2 Each periodical survey should include a close-up examination of sufficient extent to establish the condition of the shell frames and their end attachments in all cargo holds and ballast tanks as indicated in annex 1.

2.6 Extent of thickness measurements

2.6.1 The requirements for thickness measurements at the periodical survey are given in annex 2.

2.6.2 Representative thickness measurements to determine both general and local levels of corrosion in the shell frames and their end attachments in all cargo holds and ballast tanks should be carried out. Thickness measurement should also be carried out to determine the corrosion levels on the transverse bulkhead plating. The thickness measurements may be dispensed with provided the surveyor is satisfied by the close-up examination, that there is no structural diminution, and the coating where applied remains efficient.

2.6.3 The surveyor may extend the thickness measurements as deemed necessary.

2.6.4 For areas in spaces where coatings are found to be in GOOD condition as defined in 1.2.11, the extent of thickness measurements according to annex 2 may be specially considered by the Administration.

2.6.5 Transverse sections should be chosen where the largest reductions are suspected to occur or are revealed from deck plating measurements.

2.7 Extent of tank pressure testing

2.7.1 All boundaries of ballast tanks, deep tanks and cargo holds used for ballast within the cargo hold length should be pressure tested. Representative tanks for fresh water, fuel oil and lubrication oil should also be pressure tested.

2.7.2 Generally, the pressure should correspond to a water level to the top of hatches for ballast/cargo holds, or top of air pipes for ballast tanks or fuel tanks.

3 ENHANCED SURVEY CARRIED OUT DURING ANNUAL SURVEY

3.1 General

3.1.1 The survey should consist of an examination for the purpose of ensuring, as far as practicable, that the hull hatch covers, coamings and piping are maintained in a satisfactory condition and should take into account the service history, condition and extent of the corrosion prevention system of ballast tanks and areas identified in the survey report file.

3.2 Examination of the hull

3.2.1 Examination of the hull plating and its closing appliances should be carried out as far as can be seen.

3.2.2 Examination of watertight penetrations should be carried out as far as practicable.

3.3 Examination of hatch covers and coamings

3.3.1 It should be confirmed that no unapproved changes have been made to the hatch covers, hatch coamings and their securing and sealing devices since the last survey.

3.3.2 Where mechanically operated steel covers are fitted, the satisfactory condition of the following should be confirmed:

- hatch covers;
- tightness devices of longitudinal, transverse and intermediate cross junctions (gaskets, gasket lips, compression bars, drainage channels);
- clamping devices, retaining bars, cleating;
- chain or rope pulleys;
- guides;
- guide rails and track wheels;
- stoppers, etc;
- wires, chains, gypsies, tensioning devices;
- hydraulic system essential to closing and securing;
- safety locks and retaining devices.

3.3.3 Where portable covers, wooden or steel pontoons are fitted, the satisfactory condition of the following should be confirmed:

- wooden covers and portable beams, carriers or sockets for the portable beam, and their securing devices;
- steel pontoons;
- tarpaulins;
- cleats, battens and wedges;
- hatch securing bars and their securing devices;
- loading pads/bars and the side plate edge;
- guide plates and chocks;
- compression bars, drainage channels and drain pipes (if any).

3.3.4 If considered necessary by the surveyor the effectiveness of sealing arrangements of all hatch covers should be confirmed.

3.4 Examination of cargo holds

3.4.1 For bulk carriers over 10 years of age, an overall survey of a representative forward and after cargo hold should be carried out. Where this level of survey reveals the need for remedial measures, the survey should be extended to include an overall survey of all cargo holds.

3.4.2 For bulk carriers over 15 years of age, the following should be carried out:

- .1 overall survey of all cargo holds; and
- .2 close-up examination of sufficient extent to establish the condition of the lower region of the shell frames and their end attachments in a forward cargo hold. Where this level of survey reveals the need for remedial measures, the survey should be extended to include a close-up survey of all cargo holds.

3.5 Examination of ballast tanks

3.5.1 Examination of ballast tanks should be carried out when required as a consequence of the results of the periodical survey and intermediate enhanced survey. When extensive corrosion is found, thickness measurements should be carried out.

4 INTERMEDIATE ENHANCED SURVEY

4.1 General

4.1.1 Those items which are additional to the requirements of the annual survey may be surveyed either at the second or third annual survey or between these surveys.

4.1.2 In the case of bulk carriers over 5 years of age the intermediate enhanced survey should include, in addition to the requirements of the annual surveys, an examination of the items specified in 4.2, 4.3 and 4.4.

4.2 Ballast tanks

4.2.1 An overall survey of representative ballast tanks selected by the surveyor should be carried out. For ships over 10 years of age, all ballast tanks should be examined. If such inspections reveal no visible structural defects, the examination may be limited to a verification that the coating remains efficient.

4.2.2 Where POOR coating condition as defined in 1.2.11, corrosion or other defects are found in ballast tanks or where a coating has not been applied from the time of construction, the examination should be extended to other ballast tanks of the same type.

4.2.3 For ballast tanks excluding double bottom tanks, where a coating is found in POOR condition as defined in 1.2.11, and it is not renewed or where a coating has not been applied, the tanks in question should be examined at annual intervals. When such breakdown of coating is found in ballast double bottom tanks, or where a coating has not been applied the tanks in question may be examined at annual intervals. Thickness measurements should be carried out as considered necessary by the surveyor.

4.2.4 In addition to the requirements above, areas found suspect according to 1.2.8 at the previous periodical survey should be subject to overall and close-up surveys.

4.3 Cargo holds

4.3.1 An overall survey of all cargo holds, including a close-up survey of sufficient extent, should be carried out to establish the condition of:

- shell frames and their end attachments and transverse bulkheads in the forward cargo hold and one other selected cargo hold;
- areas found suspect according to 1.2.8 at the previous periodical survey.

4.3.2 Where considered necessary by the surveyor as a result of the overall and close-up surveys as described in 4.3.1, the survey should be extended to include a close-up survey of sufficient extent of other representative cargo holds.

4.4 Extent of thickness measurements

4.4.1 Thickness measurements should be carried out to an extent sufficient to determine both general and local corrosion levels at areas subject to close-up survey, as described in 4.2.4, 4.3.1 and 4.3.2.

4.4.2 The thickness measurements may be dispensed with provided the surveyor is satisfied by the close-up survey, that there is no structural diminution and the coating where applied remains effective.

5 PREPARATIONS FOR SURVEY

5.1 Planning

5.1.1 A specific survey programme should be worked out in advance of the periodical survey by the owner in co-operation with the Administration.

5.1.2 The survey programme should include conditions for survey, access to structures and equipment for surveys, taking into account the requirements of annexes 1 and 2 for close-up survey and thickness measurements and tank pressure testing as described in 2.7.

5.1.3 Alternatively the close-up survey in this survey programme may be based on a planning document, approved by the Administration, as described in annex 4. The planning document should comply with a procedure for the application of risk assessment developed by the Organization.

5.1.4 The survey programme should take into account the information included in the documentation on board, as described in 6.2 and 6.3.

5.2 Conditions for survey

5.2.1 The owner should provide the necessary facilities for a safe execution of the survey.

5.2.2 Tanks and spaces should be safe for access, i.e. gas freed, ventilated, etc.

5.2.3 Tanks and spaces should be sufficiently clean and free from water, scale, dirt, oil residues, etc., to reveal significant corrosion, deformation, fractures, damages or other structural deterioration. In particular this applies to areas which are subject to thickness measurement.

5.2.4 Sufficient illumination should be provided to reveal significant corrosion, deformation, fractures, damages or other structural deterioration.

5.3 Access to structures

5.3.1 For overall survey, means should be provided to enable the surveyor to examine the structure in a safe and practical way.

5.3.2 For close-up survey, one or more of the following means for access, acceptable to the surveyor, should be provided:

- permanent staging and passages through structures
- temporary staging and passages through structures
- lifts and moveable platforms
- other equivalent means.

5.4 Equipment for survey

5.4.1 Thickness measurements should normally be carried out by means of ultrasonic test equipment. The accuracy of the equipment should be proven to the surveyor as required.

5.4.2 One or more of the following fracture detection procedures may be required if deemed necessary by the surveyor:

- radiographic equipment
- ultrasonic equipment
- magnetic particle equipment
- dye penetrant
- other equivalent means

5.5 Survey at sea or at anchorage

5.5.1 Survey at sea or at anchorage may be accepted provided the surveyor is given the necessary assistance from the personnel on board. Necessary precautions and procedures for carrying out the survey should be in accordance with 5.1, 5.2, 5.3 and 5.4.

5.5.2 A communication system should be arranged between the survey party in the spaces and the responsible officer on deck.

5.5.3 Explosimeter, oxygen-meter, breathing apparatus, lifeline and whistles should be at hand during the survey. A safety checklist should be provided.

6 DOCUMENTATION ON BOARD

6.1 General

6.1.1 The owner should supply and maintain on-board documentation as specified in 6.2 and 6.3, which should be readily available for the surveyor. The condition evaluation report referred to in 6.2 should include a translation into English.

W/0372a

6.1.2 The documentation should be kept on board for the lifetime of the ship.

6.2 Survey report file

6.2.1 A survey report file should be a part of the documentation on board consisting of:

- .1 reports of structural surveys (annex 6);
- .2 condition evaluation report (annex 7);
- .3 thickness measurement reports (annex 8); and
- .4 survey planning document according to principles in annex 4, where provided.

6.2.2 The survey report file should be available also in the owner's and the Administration offices.

6.3 Supporting documents

6.3.1 The following additional documentation should be available on board:

- .1 main structural plans of holds and ballast tanks
- .2 previous repair history
- .3 cargo and ballast history
- .4 inspections by ship's personnel with reference to:
 - structural deterioration in general;
 - leakages in bulkheads and piping;
 - condition of coating or corrosion prevention system, if any,a guidance for reporting is shown in annex 3;

and any other information that would help to identify critical structural areas and/or suspect areas requiring inspection.

6.4 Review of documentation on board

6.4.1 Prior to inspection, the surveyor should examine the completeness of the documentation on board, and its contents as a basis for the survey.

7 PROCEDURES FOR THICKNESS MEASUREMENTS

7.1 General

7.1.1 Thickness measurements should normally be carried out under the supervision of the surveyor. However, the surveyor may accept thickness measurements not carried out under his direct supervision provided that:

- .1 the thickness measurements are carried out by a qualified company certified by an organization recognized by the Administration,

- .2 the thickness measurements are carried out within 12 months prior to completion of the periodical survey specified in section 2 or intermediate enhanced survey specified in section 4.

The surveyor should recheck the measurements as deemed necessary to ensure acceptable accuracy.

7.2 Certification of thickness measurement company

7.2.1 The thickness measurements should be carried out by a qualified company certified by an organization recognized by the Administration according to principles stated in annex 5.

7.3 Reporting

7.3.1 A thickness measurement report should be prepared and submitted to the Administration. The report should give the location of measurements, the thickness measured as well as corresponding original thickness. Furthermore, the report should give the date when the measurements were carried out, type of measuring equipment, names of personnel and their qualifications and be signed by the operator. The thickness measurement report should follow the principles as specified in the recommended procedures for thickness measurements set out in annex 8.

7.3.2 The surveyor should verify and countersign the thickness measurement reports.

8 REPORTING AND EVALUATION OF SURVEY

8.1 Evaluation of survey report

8.1.1 The data and information on the structural condition of the ship collected during the survey should be evaluated for acceptability and continued structural integrity of the ship.

8.1.2 The analysis of data should be carried out and endorsed by the Administration and the conclusions of the analysis should form a part of the condition evaluation report.

8.2 Reporting

8.2.1 Principles for survey reporting are shown in annex 6.

8.2.2 A condition evaluation report of the survey and results should be issued to the owner as shown in annex 7 and placed on board the ship for reference at future surveys. The condition evaluation report should be endorsed by the Administration.

ANNEX 1

REQUIREMENTS FOR CLOSE-UP SURVEY AT PERIODICAL SURVEYS

AGE ≤ 5	5 < AGE ≤ 10	10 < AGE ≤ 15	AGE > 15
1	2	3	4
(A) - 25% of frames in the forward cargo hold at representative positions.	(A) - 25% of frames in the forward cargo hold at representative positions.	(A) - 25% of frames in all cargo holds.	(A) - All frames in all cargo holds
(A) - Selected frames in remaining cargo holds.	(A) - Selected frames in remaining cargo holds.	(B) - All transverse webs with associated plating and longitudinals in each water ballast tank (i.e. topside, hopper side or side tank).	Points (B) to (E) referred to in column 3
(B) - One transverse web with associated plating and longitudinals in two representative water ballast tanks of each type (i.e. topside, hopper side or side tank).	(B) - One transverse web with associated plating and longitudinals in each water ballast tank (i.e. topside, hopper side or side tank).	(C) - All transverse bulkheads in ballast tanks, including stiffening system.	
(C) - Two selected cargo hold transverse bulkheads.	(B) - Forward and aft transverse bulkhead in one side ballast tank, including stiffening system.	(C) - All cargo hold transverse bulkheads.	
	(C) - One transverse bulkhead in each cargo hold.	(D) - All cargo hold hatch covers and coamings.	
	(D) - Selected cargo hold hatch covers and coamings.	(E) - All deck plating inside line of hatch openings between cargo hold hatches.	
	(E) - Selected areas of deck plating inside line of hatch openings between cargo hold hatches.		

(A) - Cargo hold transverse frames.

(B) - Transverse web or watertight transverse bulkhead in water ballast tanks.

(C) - Cargo hold transverse bulkheads, platings, stiffeners and girders.

(D) - Cargo hold hatch covers and coamings.

(E) - Deck plating inside line of hatch openings between cargo hold hatches.

ANNEX 2

REQUIREMENTS FOR THICKNESS MEASUREMENTS AT PERIODICAL SURVEYS

AGE \leq 5	5 < AGE \leq 10	10 < AGE \leq 15	AGE > 15
1	2	3	4
1. Suspect areas	1. Suspect areas 2. Within the cargo length area: .1 Two transverse sections of deck plating outside line of cargo hatch openings. 3. Measurement, for general assessment and recording of corrosion pattern, of those structural members subject to close-up survey according to annex 1. 4. Selected cargo hold hatch covers and coamings (plating and stiffeners). 5. Selected areas of deck plating inside line of openings between cargo hold hatches. 6. All wind and water strakes within the cargo length area.	1. Suspect areas 2. Within the cargo length area: .1 Each deck plate outside line of cargo hatch openings .2 Two transverse sections, one of which should be in the amidship area, outside line of cargo hatch openings. 3. Measurement, for general assessment and recording of corrosion pattern, of those structural members subject to close-up survey according to annex 1. 4. All cargo hold hatch covers and coamings (plating and stiffeners). 5. All deck plating inside line of openings between cargo hold hatches. 6. All wind and water strakes within the cargo length area. 7. Selected wind and water strakes outside the cargo length area.	1. Suspect areas 2. Within the cargo length area: .1 Each deck plate outside line of cargo hatch openings .2 Three transverse sections, one of which should be in the amidship area, outside line of cargo hatch openings .3 Each bottom plate 3. Points 3 to 7 referred to in column 3

ANNEX 3

OWNER'S INSPECTION REPORT

Structural condition

Ship's name:							
OWNERS'S INSPECTION REPORT - Structural condition							
For tank/hold No.:							
Grade of steel:	Deck	:.....	Side	:.....			
	Bottom	:.....	Longitudinal bulkhead	:.....			
Elements	Cracks	Buckles	Corrosion	Coating condition	Pitting	Modification/repair	Other
Deck:							
Bottom:							
Side:							
Side framing:							
Longitudinal bulkheads:							
Transverse bulkheads:							
Repairs carried out due to:							
Thickness measurements carried out (dates):							
Results in general:							
Overdue surveys:							
Outstanding conditions of class:							
Comments:							
Date of inspection:							
Inspected by:							
Signature:							

ANNEX 4

PRINCIPLES FOR PLANNING DOCUMENT

1 A planning document is intended to identify critical structural areas and to stipulate the minimum extent, locations and means for close-up survey and thickness measurements with respect to sections and internal structures as well as nominate suspect areas.

2 The document should be worked out by the owner in co-operation with the Administration well in advance of the survey.

3 The basis for nomination of spaces and areas referred to in 1 is a risk assessment in consideration of possible deteriorations where the following elements on the particular ship are taken into account:

- .1 design features such as extent of high tensile steel and local details;
- .2 former history available at owner's and Administration offices with respect to corrosion, cracking, buckling, indents and repairs for the particular ship as well as similar ships;
- .3 information from same offices with respect to type of cargo, use of different tanks/holds, corrosion prevention system and condition of coating, if any.

4 The degree of criticality should be judged and decided on the basis of recognized principles and practice.

5 The planning document should contain:

- .1 main particulars;
- .2 plan of tanks/holds;
- .3 list of tanks/holds with information on use, protection and condition of coating;
- .4 corrosion risk nomination of tanks;
- .5 design risk nomination of structures;
- .6 nomination of tanks and areas for close-up survey;
- .7 nomination of sections and structures for thickness measurements; and
- .8 list of acceptable corrosion allowance of different structures.

ANNEX 5

PROCEDURES FOR CERTIFICATION OF A COMPANY ENGAGED IN THICKNESS MEASUREMENT OF HULL STRUCTURES

1 Application

This guidance applies for certification of the company which intends to engage in the thickness measurement of hull structures of ships.

2 Procedures for certification

Submission of documents

2.1 The following documents should be submitted to an organization recognized by the Administration for approval.

- .1 Outline of the company, e.g. organization and management structure.
- .2 Experience of the company on thickness measurement of hull structures of ships.
- .3 Technicians careers, i.e. experience of technicians as thickness measurement operators, technical knowledge and experience of hull structure, etc. Operators should be qualified according to a recognized industrial NDT Standard.
- .4 Equipment used for thickness measurement such as ultra-sonic testing machines and their maintenance/calibration procedures.
- .5 A guide for thickness measurement operators.
- .6 Training programmes for technicians for thickness measurement.
- .7 Measurement record format in accordance with recommended procedures for thickness measurements (see annex 8).

Auditing of the company

2.2 Upon reviewing the documents submitted with satisfactory results, the company should be audited in order to ascertain that the company is duly organized and managed in accordance with the documents submitted, and eventually is capable of conducting thickness measurement of the hull structure of ships.

2.3 Certification is conditional upon an on-board demonstration of thickness measurement as well as satisfactory reporting.

3 Certification

3.1 Upon satisfactory results of both the audit of the company referred to in 2.2 and the demonstration tests referred to in 2.3, the Administration or organization recognized by the Administration should issue a Certificate of Approval as well as a notice to the effect that the thickness measurement operation system of the company has been certified.

3.2 Renewal/endorsement of the certificate should be made at intervals not exceeding 3 years by verification that original conditions are maintained.

4 Report of any alteration to the certified thickness measurement operation system

In case where any alteration to the certified thickness measurement operation system of the company is made, such an alteration should be immediately reported to the organization recognized by the Administration. Re-audit should be made where deemed necessary by the organization recognized by the Administration.

5 Withdrawal of the certification

The certification may be withdrawn in the following cases:

- .1 where the measurements were improperly carried out or the results were improperly reported;
- .2 where the surveyor found any deficiencies in the approved thickness measurement operation systems of the company;
- .3 where the company failed to report any alteration referred to in 4 to the organization recognized by the Administration as required.

ANNEX 6

REPORTING PRINCIPLES

Reporting formats should be worked out individually by the Administration. As a principle the following contents of reports for bulk carrier structures should be included as applicable for the survey.

- 1 Type of survey (periodical survey, intermediate enhanced survey, annual survey, other)
 - 1.1 Date, location, whether or not the survey was in dry-dock and whether or not the survey was completed.
 - 1.2 Date of the previous:
 - bottom inspection
 - dry-docking
- 2 Extent of the survey
 - 2.1 Identification of overall surveyed spaces.
 - 2.2 Where in each hold close-up survey has been carried out, and means of access.
 - 2.3 Identification of spaces and location of structures to be given with respect to the thickness measurements carried out.
 - 2.4 Identification of pressure tested spaces.
- 3 Results of the survey
 - 3.1 Coating condition of each space (if applicable). Identification of tanks with anodes.
 - 3.2 Structural condition of each space:
 - identified space found in satisfactory condition. Otherwise identification of findings which should be corrected or recorded, such as:
 - corrosion: - structure members
 - type of corrosion (pitting, general)
 - extent
 - cracks (location)
 - buckling (location)
 - indents (location)

The narrative report may be supplemented by sketches/photos of damages/repairs.

3.3 Thickness measurement report endorsed by the attending surveyor.

4 Actions to possible findings

4.1 Repair in identified spaces:

- structural member
- repair method
- repair extent.

4.2 Recorded findings considered not to necessitate immediate repairs. Memoranda for future inspections and thickness measurements should be given, e.g. for areas found as suspect with respect to corrosion (see 1.2.8).

4.3 Condition of class/flag State requirements.

The structure of the reporting contents may be different, depending on the report system for the Administration.

ANNEX 7

CONDITION EVALUATION REPORT
 Issued upon completion of periodical survey

General particulars

Ship's name:	Class/Administration identity number: Previous class/Administration identity number(s): IMO number:
Port of registry:	National flag: Previous national flag(s):
Deadweight (metric tonnes):	Gross tonnage: National: ITC (1969):
Date of build:	Classification notation:
Date of major conversion:	
Type of conversion:	Owner: Previous owner(s):

1 The survey reports and documents listed below have been reviewed by the undersigned and found to be satisfactory

2 The periodical survey has been completed in accordance with the present Guidelines on (date)

Condition evaluation report completed by	Name Signature	Title
Office	Date	
Condition evaluation report verified by	Name Signature	Title
Office	Date	

Attached reports and documents:

- 1)
- 2)
- 3)
- 4)
- 5)
- 6)

Contents of condition evaluation report

Part 1	-	General particulars:	-	See front page
Part 2	-	Report review:	-	Where and how survey was done
Part 3	-	Close-up survey:	-	Extent (which tanks/holds)
Part 4	-	Thickness measurements:	-	Reference to thickness measurement report
			-	Summary of where measured
			-	Separate form indicating the spaces with substantial corrosion, and corresponding:
			-	thickness diminution
			-	corrosion pattern
Part 5	-	Tank corrosion prevention system:	-	Separate form indicating:
			-	location of coating/anodes
			-	condition of coating (if applicable)
Part 6	-	Repairs:	-	Identification of spaces/areas
Part 7	-	Condition of class/flag State requirements:		
Part 8	-	Memoranda:	-	Acceptable defects
			-	Any points of attention for future surveys, e.g. for suspect areas
			-	Extended annual/intermediate enhanced survey due to coating breakdown
Part 9	-	Conclusion:	-	Statement on evaluation/verification of survey report

Extract of thickness measurements

Reference is made to the thickness measurement report:

Position of substantially corroded tanks/areas ^{1/}	Thickness diminution [%]	Corrosion pattern ^{2/}	Remarks: e.g. Ref. attached sketches

Remarks

^{1/} Substantial corrosion, i.e. 75% - 100% of acceptable margins wasted.

^{2/} P = Pitting
 C = Corrosion in general

Tank/hold corrosion prevention system

Tank/hold ^{1/} Nos.	Tank/hold corrosion prevention system ^{2/}	Coating condition ^{3/}	Remarks

Remarks

1/ All ballast tanks and cargo holds should be listed.

2/ C = Coating A = Anodes NP = No protection

3/ Coating condition according to the following standard.

GOOD condition with only minor spot rusting.

FAIR condition with local breakdown of coating at edges of stiffeners and weld connections and/or light rusting over 20% or more of areas under consideration, but less than as defined for POOR condition.

POOR condition with general breakdown of coating over 20% or more of areas or hard scale at 10% or more of areas under consideration.

If coating condition "POOR" is given, extended annual surveys should be introduced. This should be noted in part 7 of the Contents of condition evaluation report.

ANNEX 8

RECOMMENDED PROCEDURES FOR THICKNESS MEASUREMENTS

General

- 1 These procedures should be used for recording thickness measurements as required by annex 2.
- 2 Reporting forms TM1-BC, TM2-BC, TM3-BC, TM4-BC, TM5-BC, TM6-BC and TM7-BC, set out in appendix 2 should be used for recording thickness measurements.
- 3 Appendix 3 contains guidance diagrams and notes relating to the reporting forms and the requirements for thickness measurement.
- 4 The reporting forms should, where appropriate, be supplemented by data presented on structural sketches.

- Appendix 1 General particulars
- Appendix 2 Reports on thickness measurement
- Appendix 3 Guidance on thickness measurement

APPENDIX 1

GENERAL PARTICULARS

Ship's name:

IMO number:

Class/Administration identity number:

Port of registry:

Gross tonnage:

Deadweight:

Date of build:

Classification society:

Name of company performing thickness measurement:

Thickness measurement company certified by:

Certificate number:

Certificate valid from:..... to

Place of measurement:

First date of measurement:

Last date of measurement:

Periodical survey/intermediate enhanced survey due*:

Details of measurement equipment:

Qualification of operator:

Report number: consisting of pages

Name of operator: Name of surveyor

Signature of operator: Signature of surveyor

Company official stamp: Administration:
Official stamp:

* Delete as appropriate.

APPENDIX 2

REPORTS ON THICKNESS MEASUREMENT

Report on thickness measurement of all deck plating, all bottom shell plating or side shell plating (TM1-BC)

Ship's name IMO number Class Identity No. Report No.

STRAKE POSITION																	
	PLATE POSITION	No or Letter	Org. Thk. mm	Forward Reading						Aft Reading						Mean diminution	
				Gauged		Diminution P		Diminution S		Gauged		Diminution P		Diminution S		P	S
				P	S	mm	%	mm	%	P	S	mm	%	mm	%	P	S
12th forward																	
11th																	
10th																	
9th																	
8th																	
7th																	
6th																	
5th																	
4th																	
3rd																	
2nd																	
1st																	
Amidships																	
1st aft																	
2nd																	
3rd																	
4th																	
5th																	
6th																	
7th																	
8th																	
9th																	
10th																	
11th																	
12th																	

Operator's signature

Surveyor's signature

NOTES - See reverse

NOTES

- 1 This report should be used for recording the thickness measurement of:
 - .1 All strength deck plating within the cargo length area.
 - .2 Keel, bottom shell plating and bilge plating within the cargo length area.
 - .3 Side shell plating that is all wind and water strakes within the cargo length area.
 - .4 Side shell plating that is selected wind and water strakes outside the cargo length area.
- 2 The strake position should be clearly indicated as follows:
 - 2.1 For strength deck indicate the number of the strake of plating inboard from the stringer plate.
 - 2.2 For bottom plating indicate the number of the strake of plating outboard from the keel plate.
 - 2.3 For side shell plating give number of the strake of plating below sheerstrake and letter as shown on shell expansion.
- 3 Only the deck plating strakes outside line of openings should be recorded.
- 4 Measurements should be taken at the forward and aft areas of all plates and the single measurements recorded should represent the average of multiple measurements.

Report on thickness measurement of shell and deck plating (one, two or three transverse sections) (IM2-BC(1))

Ship's name IMO number Class identity No. Report No.

STRENGTH DECK AND SHEERSTRAKE PLATING																										
STRAKE POSITION	FIRST TRANSVERSE SECTION AT FRAME NUMBER								SECOND TRANSVERSE SECTION AT FRAME NUMBER						THIRD TRANSVERSE SECTION AT FRAME NUMBER											
	No. or Letter	Org. Thk.	Gauged		Diminution P		Diminution S		No. or Letter	Org. Thk.	Gauged		Diminution P		Diminution S		No. or Letter	Org. Thk.	Gauged		Diminution P		Diminution S			
			P	S	mm	%	mm	%			P	S	mm	%	mm	%			P	S	mm	%	mm	%		
Stringer plate																										
1st strake inboard																										
2nd																										
3rd																										
4th																										
5th																										
6th																										
7th																										
8th																										
9th																										
10th																										
11th																										
12th																										
13th																										
14th																										
centre strake																										
sheer strake																										
TOPSIDE TOTAL																										

Operator's signature

Surveyor's signature

NOTES - See reverse

NOTES

1 This report should be used for recording the thickness measurement of strength deck plating and sheerstrake plating transverse sections:

Two or three sections within the cargo length area, comprising of the structural items (1), (2) and (3) as shown on the diagram of typical transverse section indicating longitudinal and transverse members, in appendix 3.

2 Only the deck plating outside the line of openings should be recorded.

3 The topside area comprises deck plating, stringer plate and sheerstrake (including rounded gunwales).

4 The exact frame station of measurement should be stated.

5 The single measurements recorded should represent the average of multiple measurements.

Report on thickness measurement of shell and deck plating (one, two or three transverse sections) (TM2-BC(2))

Ship's name IMO number Class identity No. Report No.

STRAKE POSITION	SHELL PLATING																								
	FIRST TRANSVERSE SECTION AT FRAME NUMBER								SECOND TRANSVERSE SECTION AT FRAME NUMBER						THIRD TRANSVERSE SECTION AT FRAME NUMBER										
	No. or Letter	Org. Thk.	Gauged		Diminution P		Diminution S		No. or Letter	Org. Thk.	Gauged		Diminution P		Diminution S		No. or Letter	Org. Thk.	Gauged		Diminution P		Diminution S		
			P	S	mm	%	mm	%			P	S	mm	%	mm	%			P	S	mm	%	mm	%	
1st below sheer strake																									
2nd																									
3rd																									
4th																									
5th																									
6th																									
7th																									
8th																									
9th																									
10th																									
11th																									
12th																									
13th																									
14th																									
15th																									
16th																									
17th																									
18th																									
19th																									
20th																									
keel strake																									
BOTTOM TOTAL																									

Operator's signature

Surveyor's signature

NOTES - See reverse

NOTES

1 This report should be used for recording the thickness measurements of shell plating transverse sections:

Two or three sections within the cargo length area comprising of the structural items (4), (5), (6), and (7) as shown on the diagram of typical transverse section indicating longitudinal and transverse members, in appendix 3.

2 The bottom area comprises keel, bottom and bilge plating.

3 The exact frame station of measurement should be stated.

4 The single measurements recorded should represent the average of multiple measurements.

Report on thickness measurement of longitudinal members (one, two or three transverse sections) (IM3-BC)

Ship's name IMO number Class identity No. Report No.

STRUCTURAL MEMBER	FIRST TRANSVERSE SECTION AT FRAME NUMBER								SECOND TRANSVERSE SECTION AT FRAME NUMBER								THIRD TRANSVERSE SECTION AT FRAME NUMBER							
	Item No.	Org. Thk.	Gauged		Diminution P		Diminution S		Item No.	Org. Thk.	Gauged		Diminution P		Diminution S		Item No.	Org. Thk.	Gauged		Diminution P		Diminution S	
			P	S	mm	%	mm	%			P	S	mm	%	mm	%			P	S	mm	%	mm	%

Operator's signature

Surveyor's signature

NOTES - See reverse

NOTES

1 This report should be used for recording the thickness measurement of longitudinal members at transverse sections:

Two or three sections within the cargo length area, comprising of the structural items (8) to (20) as shown on the diagram of typical transverse section indicating longitudinal and transverse members, in appendix 3.

2 The exact frame station of measurement should be stated.

3 The single measurements recorded should represent the average of multiple measurements.

**Report on thickness measurement of transverse structural members
 in the cargo and ballast tanks within the cargo tank length (TM4-BC)**

Ship's name IMO number Class Identity No. Report No.

A 18/Res.744

TANK DESCRIPTION :								
LOCATION OF STRUCTURE :								
STRUCTURAL MEMBER	ITEM	Original Thickness mm	Gauged		Diminution P		Diminution S	
			P	S	mm	%	mm	%

Operator's signature

Surveyor's signature

NOTES - See reverse

NOTES

- 1 This report should be used for recording the thickness measurement of transverse structural members, comprising of the appropriate structural items (23) to (25) as shown on the diagram of typical transverse section indicating longitudinal and transverse members, in appendix 3.
- 2 Guidance for areas of measurement is indicated in tables 1 to 3 of appendix 3.
- 3 The single measurements recorded should represent the average of multiple measurements.

Report on thickness measurement of cargo hold transverse bulkheads (TM5-BC)

Ship's name IMO number Class identity No. Report No.

TANK/HOLD DESCRIPTION :						FRAME No. :	
LOCATION OF STRUCTURE :							
STRUCTURAL COMPONENT (PLATING/STIFFENER)	Original Thickness mm	Gauged		Diminution P		Diminution S	
		Port	Starboard	mm	%	mm	%

Operator's signature

Surveyor's signature

NOTES - See reverse

NOTES

- 1 This report form should be used for recording the thickness measurement of cargo hold transverse bulkheads.
- 2 Guidance for areas of measurement is indicated in tables 1 to 3 of appendix 3.
- 3 The single measurements recorded should represent the average of multiple measurements.

Report on thickness measurement of miscellaneous structural members (TM6-BC)

Ship's name IMO number Class identity No. Report No.

STRUCTURAL MEMBER :	SKETCH							
LOCATION OF STRUCTURE :	Org. Thk.	Gauged		Diminution P		Diminution S		
Description		P	S	mm	%	mm	%	

Operator's signature Surveyor's signature Notes - See reverse

NOTES

- 1 This report should be used for recording the thickness measurement of miscellaneous structural members including the structural items (28), (29), (30) and (31) as shown on the diagram of typical transverse section indicating longitudinal and transverse members, in appendix 3.
- 2 Guidance for areas of measurement is indicated in tables 1 to 3 of appendix 3.
- 3 The single measurements recorded should represent the average of multiple measurements.

Report on thickness measurement of cargo hold transverse frames (TM7-BC)

Ship's name IMO number Class identity No. Report No.

CARGO HOLD No.																							
		Gauged		Diminution P		Diminution S			Gauged		Diminution P		Diminution S			Gauged		Diminution P		Diminution S			
		Org. Thk.		mm	%	m	m		mm	%	mm	%	Org. Thk.			mm	%	mm	%	Org. Thk.		mm	%
		P	S										P	S						P	S		

Operator's signature

Surveyor's signature

NOTES - See reverse

A 18/Res.744

- 44 -

NOTES

- 1 This report should be used for recording the thickness measurement of:
 - cargo hold transverse frames; and
 - structural item number 34 as shown on the diagram of typical transverse section indicating longitudinal and transverse members, in appendix 3.
- 2 Guidance for areas of measurement is indicated in tables 1 to 3 of appendix 3.
- 3 The single measurements recorded should represent the average of multiple measurements.

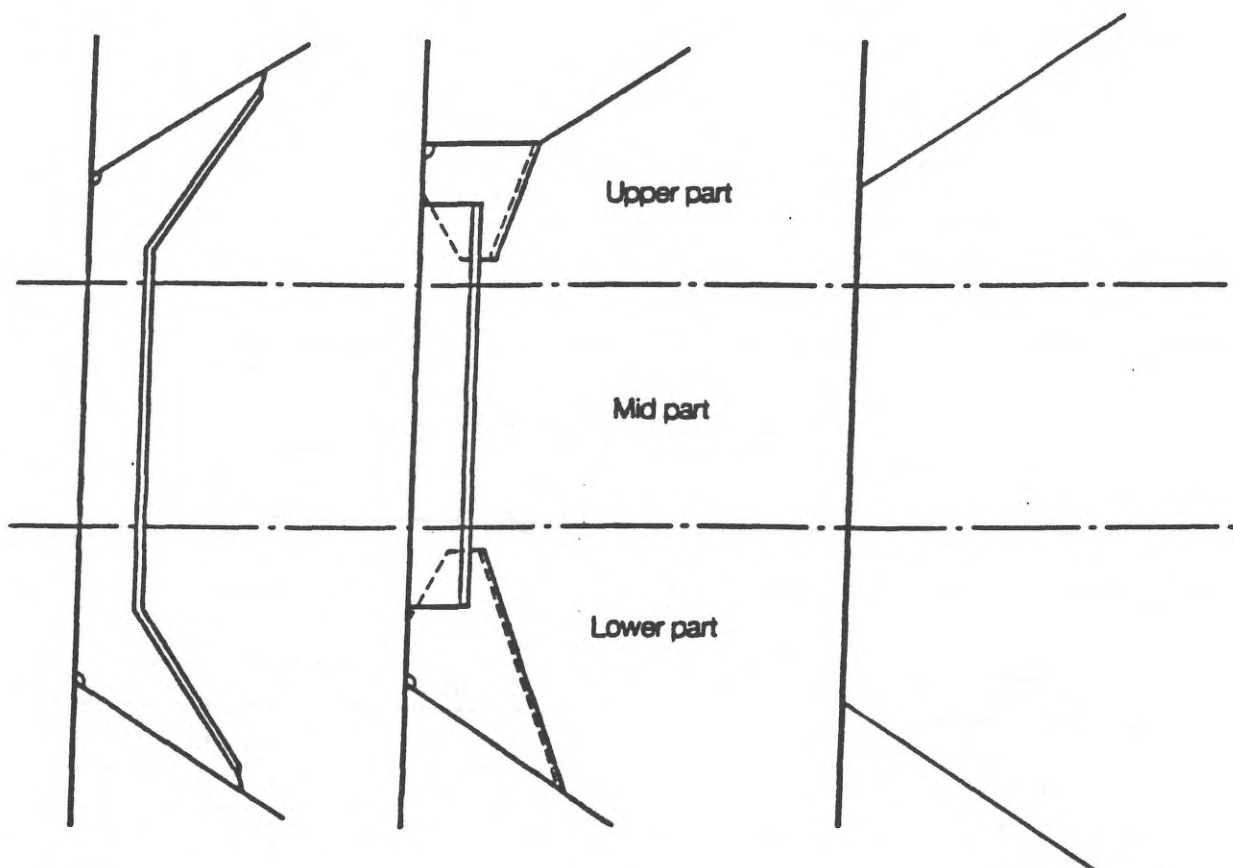

Typical transverse frames in cargo hold
Thickness gauging area (A)

Non - typical transverse
frame in cargo hold
Thickness gauging area (A)

APPENDIX 3

GUIDANCE ON THICKNESS MEASUREMENT

Typical transverse section indicating longitudinal and transverse members

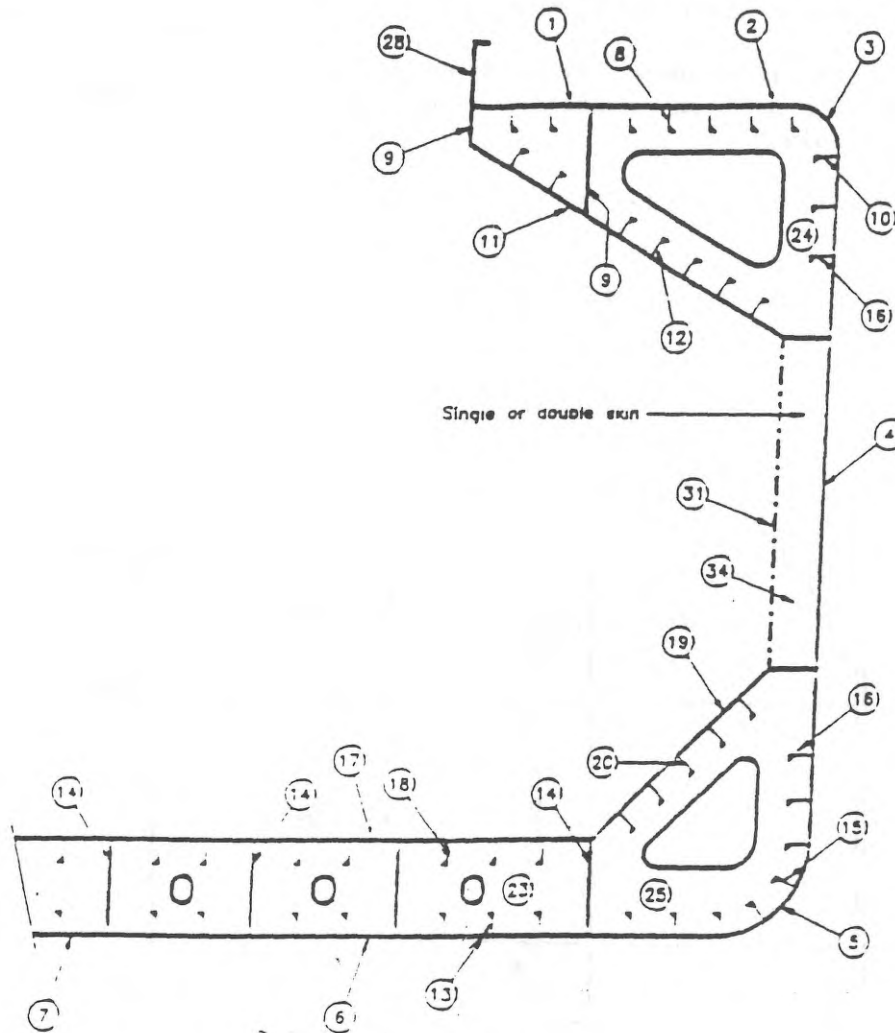

REPORT ON TM2-8C	
(1)	Strength deck plating
(2)	Stringer plate
(3)	Sheerstrake
(4)	Side shell plating
(5)	Bilge plating
(8)	Bottom shell plating
(7)	Keel plate

REPORT ON TM3-8C			
(9)	Deck longitudinals	(16)	Side shell longitudinals
(9)	Deck girders	(17)	Inner bottom plating
(10)	Sheerstrake longitudinals	(18)	Inner bottom longitudinals
(11)	Topside tank sloping plating	(19)	Hopper side plating
(12)	Topside tank sloping plating longitudinals	(20)	Hopper side longitudinals
(13)	Bottom longitudinals	(21)	
(14)	Bottom girders	(22)	
(15)	Bilge longitudinals		

REPORT ON TM4-8C	
(23)	Double bottom tank floors
(24)	Topside tank transverses
(25)	Hopper side tank transverses
(26)	
(27)	

REPORT ON TM6-8C	
(28)	Hatch coamings
(29)	Deck plating between hatches
(30)	Hatch covers
(31)	Inner bulkhead plating
(32)	
(33)	

REPORT ON TM7-8C	
(34)	Hold frames or diaphragms

Transverse section outline

(To be used for longitudinal and transverse members where the typical transverse section is not applicable)

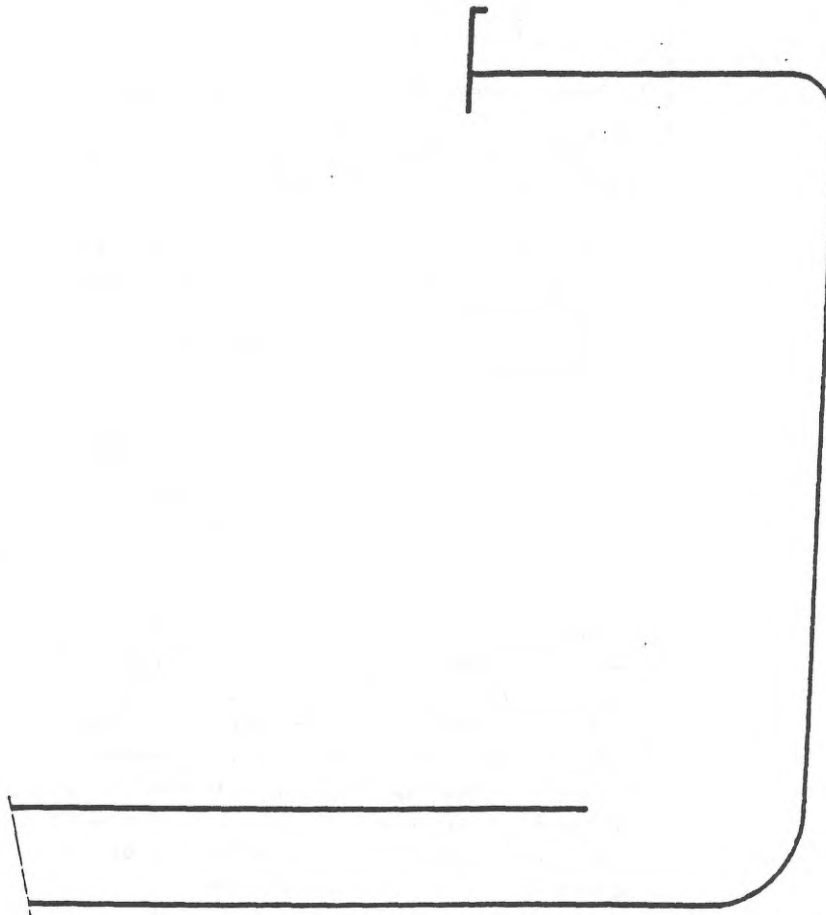

REPORT ON TM2-8C	
①	Strength deck plating
②	Stinger plate
③	Sheerstrake
④	Side shell plating
⑤	Bilge plating
⑥	Bottom shell plating
⑦	Keel plate

REPORT ON TM3-8C			
⑧	Deck longitudinals	⑮	Side shell longitudinals
⑨	Deck girders	⑰	Inner bottom plating
⑩	Sheerstrake longitudinals	⑱	Inner bottom longitudinals
⑪	Topside tank sloping plating	⑲	Hopper side plating
⑫	Topside tank sloping plating longitudinals	⑳	Hopper side longitudinals
⑬	Bottom longitudinals	㉑	
⑭	Bottom girders	㉒	
⑮	Bilge longitudinals		

REPORT ON TM4-8C	
㉓	Double bottom tank floors
㉔	Topside tank transverses
㉕	Hopper side tank transverses
㉖	
㉗	

REPORT ON TM6-8C	
㉘	Hatch coamings
㉙	Deck plating between hatches
㉚	Hatch covers
㉛	Inner bulkhead plating
㉜	
㉝	

REPORT ON TM7-8C	
㉞	Hold frames or diaphragms

Thickness measurement requirements

Table 1

AGE ≤ 5	5 < AGE ≤ 10	10 < AGE ≤ 15	AGE > 15
1	2	3	4
1. Suspect areas	1. Suspect areas 2. Within the cargo length area: .1 Two transverse sections of deck plating outside line of cargo hatch openings. 3. Measurement, for general assessment and recording of corrosion pattern, of those structural members subject to close-up survey in accordance with table 2 of this appendix. 4. Selected cargo hold hatch covers and coamings (plating and stiffeners). 5. Selected areas of deck plating inside line of openings between cargo hold hatches. 6. All wind and water strakes within the cargo length area.	1. Suspect areas 2. Within the cargo length area: .1 Each deck plate outside line of cargo hatch openings .2 Two transverse sections, one of which should be in the amidship area, outside line of cargo hatch openings. 3. Measurement, for general assessment and recording of corrosion pattern, of those structural members subject to close-up survey in accordance with table 2 of this appendix. 4. All cargo hold hatch covers and coamings (plating and stiffeners). 5. All deck plating inside line of openings between cargo hold hatches. 6. All wind and water strakes within the cargo length area. 7. Selected wind and water strakes outside the cargo length area.	1. Suspect areas 2. Within the cargo length area: .1 Each deck plate outside line of cargo hatch openings .2 Three transverse sections, one of which should be in the amidship area, outside line of cargo hatch openings. .3 Each bottom plate. 3. Points 3 to 7 referred to in column 3

Close-up survey requirements

Table 2

AGE ≤ 5	5 < AGE ≤ 10	10 < AGE ≤ 15	AGE > 15
1	2	3	4
(A) - 25% of frames in the forward cargo hold at representative positions.	(A) - 25% of frames in the forward cargo hold at representative positions	(A) - 25% of frames in all cargo holds	(A) - All frames in all cargo holds
(A) - Selected frames in remaining cargo holds.	(A) - Selected frames in remaining cargo holds.		
(B) - One transverse web with associated plating and longitudinals in two representative water ballast tanks of each type (i.e. topside, hopper side or side tank).	(B) - One transverse web with associated plating and longitudinals in each water ballast tank (i.e. topside, hopper side or side tank).	(B) - All transverse webs with associated plating and longitudinals in each water ballast tank (i.e. topside, hopper side or side tank).	(B) - All transverse webs with associated plating and longitudinals in each water ballast tank (i.e. topside, hopper side or side tank).
	(B) - Forward and aft transverse bulkhead in one side ballast tank including stiffening system.	(C) - All transverse bulkheads in all ballast tanks including stiffening system.	(C) - All transverse bulkheads in all ballast tanks including stiffening system.
(C) - Two selected cargo hold transverse bulkheads.	(C) - One transverse bulkhead in each cargo hold.	(C) - All cargo hold transverse bulkheads.	(C) - All cargo hold transverse bulkheads.
	(D) - Selected cargo hold hatch covers and coamings.	(D) - All cargo hold hatch covers and coamings.	(D) - All cargo hold hatch covers and coamings.
	(E) - Selected areas of deck plating inside line of hatch openings between cargo hold hatches.	(E) - All deck plating inside line of hatch openings between cargo hold hatches.	(E) - All deck plating inside line of hatch openings between cargo hold hatches.

(A) - Cargo hold transverse frames.

(D) - Cargo hold hatch covers and coamings.

(B) - Transverse web or watertight transverse bulkhead in water ballast tanks.

(E) - Deck plating inside line of hatch openings between cargo hold hatches.

(C) - Cargo hold transverse bulkheads, plating, stiffeners and girders.

Notes and sketches - see table 3 of this appendix

Table 3

Close-up survey and thickness measurement areas
(Typical areas for thickness measurement of cargo hold frames, structural members and transverse bulkheads in association with close-up survey requirements)

Typical transverse section

Areas (A), (B) and (D)

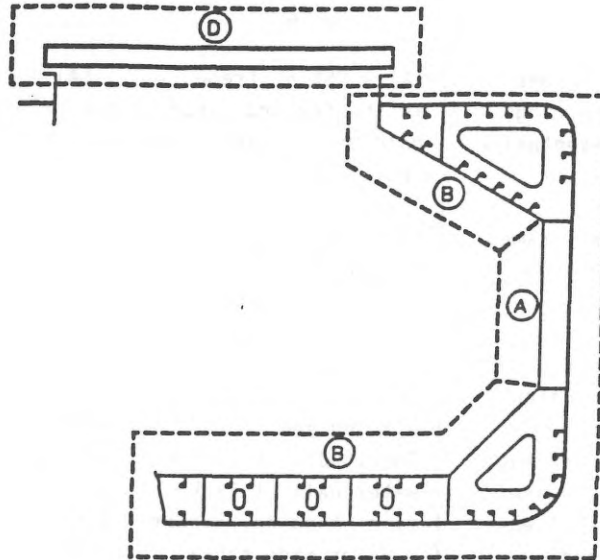

Thickness to be reported on TM3-BC, TM4-BC, TM6-BC and TM7-BC as appropriate

A cargo hold, transverse bulkhead

Area (C)

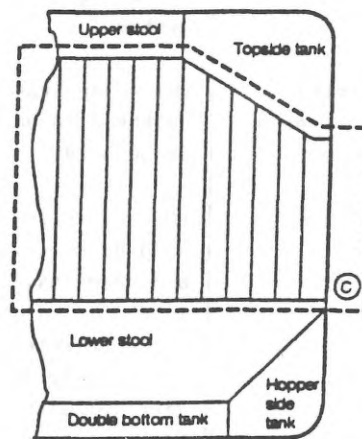

Thickness to be reported on TM5-BC

Typical areas of deck plating inside line of hatch openings between cargo hold hatches

Area (E)

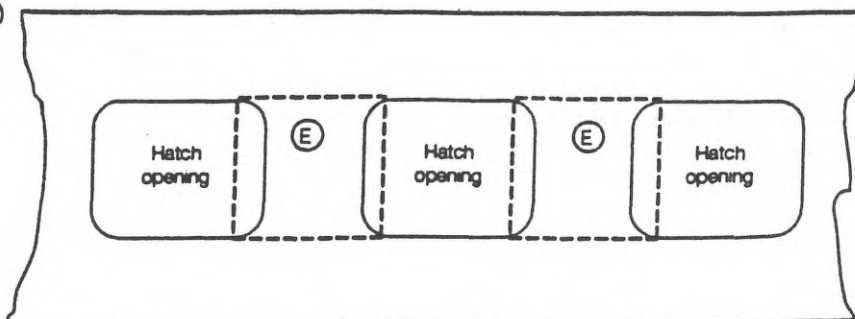

Thickness to be reported on TM6-BC

ANNEX B

GUIDELINES ON THE ENHANCED PROGRAMME OF INSPECTIONS
DURING SURVEYS OF OIL TANKERS

Contents

- 1 GENERAL
 - 1.1 Application
 - 1.2 Definitions
 - 1.3 Scope of surveys
- 2 ENHANCED SURVEY CARRIED OUT DURING PERIODICAL SURVEY
 - 2.1 General
 - 2.2 Dry-dock survey
 - 2.3 Tank corrosion prevention system
 - 2.4 Extent of overall and close-up surveys
 - 2.5 Extent of thickness measurements
 - 2.6 Extent of tank pressure testing
- 3 ENHANCED SURVEY CARRIED OUT DURING ANNUAL SURVEY
 - 3.1 General
 - 3.2 Examination of the hull
 - 3.3 Examination of weather decks
 - 3.4 Examination of cargo pump-rooms and pipe tunnels
 - 3.5 Examination of ballast tanks
- 4 INTERMEDIATE ENHANCED SURVEY
 - 4.1 General
 - 4.2 Oil tankers over 5 years of age but not more than 10 years of age
 - 4.3 Oil tankers over 10 years of age
 - 4.3.1 General
 - 4.3.2 Extent of close-up survey
 - 4.4 Extent of thickness measurements
- 5 PREPARATIONS FOR SURVEY
 - 5.1 Planning
 - 5.2 Conditions for survey
 - 5.3 Access to structures
 - 5.4 Equipment for survey
 - 5.5 Survey at sea or at anchorage
- 6 DOCUMENTATION ON BOARD
 - 6.1 General
 - 6.2 Survey report file
 - 6.3 Supporting documents
 - 6.4 Review of documentation on board

7 PROCEDURES FOR THICKNESS MEASUREMENTS

- 7.1 General
- 7.2 Certification of thickness measurement company
- 7.3 Reporting

8 REPORTING AND EVALUATION OF SURVEY

- 8.1 Evaluation of survey report
- 8.2 Reporting

Annex 1 Requirements for close-up survey at periodical surveys

Annex 2 Requirements for thickness measurements at periodical surveys

Annex 3 Requirements for tank pressure testing at periodical surveys

Annex 4 Requirements for extent of thickness measurements at areas of substantial corrosion. Periodical survey within the cargo area

Annex 5 Owner's inspection report

Annex 6 Principles for planning document

Annex 7 Procedures for certification of a company engaged in thickness measurements of hull structures

Annex 8 Reporting principles

Annex 9 Condition evaluation report

Annex 10 Recommended procedures for thickness measurements

Appendix 1 General particulars

Appendix 2 Reports on thickness measurement

Appendix 3 Guidance on thickness measurement

GUIDELINES ON THE ENHANCED PROGRAMME OF INSPECTION DURING SURVEYS OF OIL TANKERS

1 GENERAL

1.1 Application*

1.1.1 The Guidelines should apply to all oil tankers of 500 tons gross tonnage and above.

1.1.2 The compliance with the Guidelines is mandatory for crude oil tankers of 20,000 tons deadweight and above and product carriers of 30,000 tons deadweight and above under regulation 13G of Annex I to MARPOL 73/78.

1.1.3 The Guidelines should apply to surveys of hull structure and piping systems in way of cargo tanks, pump-rooms, cofferdams, pipe tunnels, void spaces within the cargo area and all ballast tanks.

1.1.4 The Guidelines contain the extent of examination, thickness measurements and tank pressure testing. The survey should be extended when substantial corrosion and/or structural defects are found and include additional close-up survey when necessary.

1.2 Definitions

1.2.1 Ballast tank is a tank which is used for water ballast and includes segregated ballast tanks, ballast double bottom spaces and peak tanks.

1.2.2 Overall survey is a survey intended to report on the overall condition of the hull structure and determine the extent of additional close-up surveys.

1.2.3 Close-up survey is a survey where the details of structural components are within the close visual inspection range of the surveyor, i.e. preferably within reach of hand.

1.2.4 Transverse section includes all longitudinal members such as plating, longitudinals and girders at the deck, side, bottom, inner bottom and longitudinal bulkheads.

1.2.5 Representative tanks are those which are expected to reflect the condition of other tanks of similar type and service and with similar corrosion prevention systems. When selecting representative tanks account should be taken of the service and repair history on board and identifiable critical and/or suspect areas.

* The intention of these guidelines is to ensure that an appropriate level of review of plans and documents is conducted and consistency in application is attained. Such evaluation of survey reports, survey programmes, planning documents, etc., should be carried out at the managerial level of the Administration or organization recognized by the Administration.

1.2.6 Suspect areas are locations showing substantial corrosion and/or are considered by the surveyor to be prone to rapid wastage.

1.2.7 Substantial corrosion is an extent of corrosion such that assessment of corrosion pattern indicates a wastage in excess of 75% of allowable margins, but within acceptable limits.

1.2.8 Corrosion prevention system is normally considered either:

- .1 a full hard coating supplemented by anodes;
- .2 a full hard coating.

Other coating systems (e.g. soft coating) may be considered acceptable as alternatives provided that they are applied and maintained in compliance with the manufacturers specification.

1.2.9 Coating condition is defined as follows:

GOOD	condition with only minor spot rusting;
FAIR	condition with local breakdown of coating at edges of stiffeners and weld connections and/or light rusting over 20% or more of areas under consideration, but less than as defined for POOR condition;
POOR	condition with general breakdown of coating over 20% or more of areas or hard scale at 10% or more of areas under consideration.

1.2.10 Critical structural areas are locations which have been identified from calculations to require monitoring or from the service history of the subject ship or from similar or sister ships to be sensitive to cracking, buckling or corrosion which would impair the structural integrity of the ship.

1.2.11 Cargo area is an area as defined in regulation II-2/3.32 of the 1974 SOLAS Convention, as amended.

1.2.12 Intermediate enhanced survey is an enhanced survey carried out either at the second or third annual survey or between these surveys.

1.3 Scope of surveys

1.3.1 Prior to inspection the surveyor should examine the completeness of documentation on board, and its contents as a basis for the survey.

1.3.2 When a survey results in the identification of significant corrosion or of significant structural defects which, in the opinion of the surveyor, will impair the structural integrity of the ship, then remedial action, in consultation with the Administration should be agreed and implemented before the ship continues in service.

2 ENHANCED SURVEY CARRIED OUT DURING PERIODICAL SURVEY

2.1 General

2.1.1 The enhanced survey may be commenced at the fourth annual survey and be progressed during the succeeding year with a view to completion by the fifth anniversary date.

2.1.2 As part of the preparation for the enhanced survey, the thickness measurement and survey programme should be dealt with, in advance of the enhanced survey. The thickness measurement should not be held before the fourth annual survey.

2.1.3 The survey should include, in addition to the requirements of the annual survey, examination, tests and checks of sufficient extent to ensure that the hull and related piping is in a satisfactory condition and is fit for its intended purpose for the new period of validity of the Certificate, subject to proper maintenance and operation and to periodical surveys being carried out.

2.1.4 All cargo tanks, ballast tanks, pump-rooms, pipe tunnels, cofferdams and void spaces bounding cargo tanks, decks and outer hull should be examined, and this examination should be supplemented by thickness measurement and testing as deemed necessary, to ensure that the structural integrity remains effective. The examination should be sufficient to discover substantial corrosion, significant deformation, fractures, damages or other structural deterioration.

2.1.5 All piping systems within the above tanks and spaces should be examined to ensure that tightness and condition remain satisfactory. Special attention should be given to ballast piping in cargo tanks and cargo piping in ballast tanks and void spaces.

2.1.6 The survey extent of combined ballast/cargo tanks should be evaluated based on the records of ballast history and extent of the corrosion prevention system provided.

2.2 Dry-dock survey

2.2.1 A survey in dry-dock should be a part of the enhanced survey during periodical survey. There should be a minimum of two inspections of the outside of the ship's bottom during the 5-year period of the certificate. In all cases, the maximum interval between bottom inspections should not exceed 36 months.

2.2.2 Alternate inspections of the ship's bottom not conducted in conjunction with the enhanced survey during periodical survey may be carried out with the ship afloat. Special consideration should be given to ships of 15 years of age or over before being permitted to have such inspections. Inspections of the ship afloat should only be carried out when the conditions are satisfactory and the proper equipment and suitably qualified staff are available.

2.2.3 If a survey in dry-dock is not completed in conjunction with the enhanced survey during periodical survey or if the 36 month maximum interval referred to in 2.2.1 is not complied with, the Cargo Ship Safety Construction Certificate issued to oil tankers referred to in paragraph 1.1.1 and/or the International Oil Pollution Prevention Certificate, as appropriate, issued to oil tankers referred to in paragraph 1.1.2 should cease to be valid until a survey in dry-dock is completed.

2.2.4 However, in order to allow time for transition to the enhanced inspection system, until 6 July 1997, the Administration with a survey cycle of 4 years or less may carry out dry dock-surveys separately from the enhanced inspections during periodical survey. For ships to which this applies, the

enhanced inspections during periodical survey should be conducted at facilities which possess the capabilities necessary to properly conduct the examinations and testing required, and all other requirements of the enhanced inspection guidelines should be met.

2.3 Tank corrosion prevention system

2.3.1 Where provided, the condition of the corrosion prevention system of cargo tanks should be examined. A ballast tank where a protective coating is found in POOR condition as defined in 1.2.9 and it is not renewed, or where a protective coating has not been applied, the tank in question should be examined at annual intervals. Thickness measurement should be carried out as deemed necessary by the surveyor.

2.4 Extent of overall and close-up surveys

2.4.1 An overall survey of all integral tanks and spaces should be carried out at the enhanced survey carried out during periodical survey.

2.4.2 The requirements for close-up surveys at the enhanced survey carried out during periodical survey are given in annex 1.

2.4.3 The surveyor may extend the scope of the close-up survey as deemed necessary taking into account the maintenance of the tanks under survey, the condition of the corrosion prevention system and also in the following cases:

- .1 in particular, tanks having structural arrangements or details which have suffered defects in similar tanks or on similar ships according to available information;
- .2 in tanks which have structures with reduced scantlings in association with a corrosion prevention system approved by the Administration.

2.4.4 For areas in tanks where coatings are found to be in GOOD condition as defined in 1.2.9, the extent of close-up surveys according to annex 1 may be specially considered by the Administration.

2.5 Extent of thickness measurements

2.5.1 The requirements for thickness measurements at the periodical survey are given in annex 2.

2.5.2 Where substantial corrosion as defined in 1.2.7 is found the extent of thickness measurements should be increased in accordance with the requirements of annex 4 or as specified in planning document as described in annex 6.

2.5.3 The surveyor may extend the thickness measurements as deemed necessary.

2.5.4 For areas in tanks where coatings are found to be in GOOD condition as defined in 1.2.9, the extent of thickness measurements according to annex 2 may be specially considered by the Administration.

2.5.5 Transverse sections should be chosen where the largest reductions are suspected to occur or are revealed from deck plating measurements.

2.5.6 In cases where two or three sections are to be measured, at least one should include a ballast tank within 0.5L amidships.

2.6 Extent of tank pressure testing

2.6.1 The requirements for tank pressure testing at the periodical survey are given in annex 3.

2.6.2 The surveyor may extend the tank pressure testing as deemed necessary.

2.6.3 Generally, the pressure should correspond to a water level to the top of access hatches for cargo tanks, or top of air pipes for ballast tanks.

3 ENHANCED SURVEY CARRIED OUT DURING ANNUAL SURVEY

3.1 General

3.1.1 The survey should consist of an examination for the purpose of ensuring, as far as practicable, that the hull and piping are maintained in a satisfactory condition and should take into account the service history, condition and extent of the corrosion prevention system of ballast tanks and areas identified in the survey report file.

3.2 Examination of the hull

3.2.1 Examination of the hull plating and its closing appliances should be carried out as far as can be seen.

3.2.2 Examination of watertight penetrations should be carried out as far as practicable.

3.3 Examination of weather decks

3.3.1 Examination of cargo tank openings including gaskets, covers, coamings and flame screens.

3.3.2 Examination of cargo tank pressure/vacuum valves and flame screens.

3.3.3 Examination of flame screens on vents to all bunker, oily ballast and oily slop tanks.

3.3.4 Examination of cargo, crude oil washing, bunker and vent piping systems, including vent masts and headers.

3.4 Examination of cargo pump-rooms and pipe tunnels

3.4.1 Examination of all bulkheads for signs of oil leakage or fractures and, in particular, the sealing arrangements of all penetrations of bulkheads.

3.4.2 Examination of the condition of all piping systems and pipe tunnels.

3.5 Examination of ballast tanks

3.5.1 Examination of ballast tanks should be carried out when required as a consequence of the results of the periodical survey and intermediate enhanced survey. When extensive corrosion is found, thickness measurements should be carried out.

3.5.2 Where substantial corrosion as defined in 1.2.7 is found, the extent of thickness measurements should be increased in accordance with the requirements in annex 4.

4 INTERMEDIATE ENHANCED SURVEY

4.1 General

4.1.1 Those items which are additional to the requirements of the annual survey may be surveyed either at the second or third annual survey or between these surveys.

4.1.2 The survey extent of cargo and ballast tanks dependent on the age of the ship is specified in 4.2 and 4.3.

4.1.3 For weather decks, an examination as far as applicable of cargo, crude oil washing, bunker, ballast, steam and vent piping systems as well as vent masts and headers. If upon examination there is any doubt as to the condition of the piping, the piping may be required to be pressure tested, thickness measured or both.

4.2 Oil tankers over 5 years of age but not more than 10 years of age

4.2.1 In the case of oil tankers over 5 years of age but not more than 10 years of age, the following should apply in addition to 4.1.3.

4.2.2 For ballast tanks, an overall survey of representative tanks selected by the surveyor should be carried out. If such inspections reveal no visible structural defects, the examination may be limited to a verification that the corrosion prevention system remains effective.

4.2.3 Where POOR coating condition as defined in 1.2.9, corrosion or other defects are found in ballast tanks or where a coating has not been applied, the examination should be extended to other ballast tanks of the same type.

4.2.4 A ballast tank where a coating is found in POOR condition as defined in 1.2.9 and it is not renewed, or where a coating has not been applied, the tank in question should be examined at annual intervals. Thickness measurements should be carried out as deemed necessary by the surveyor.

4.3 Oil tankers over 10 years of age

4.3.1 General

4.3.1.1 In the case of oil tankers over 10 years of age the following should apply in addition to 4.2.

4.3.1.2 An overall survey of at least two representative cargo tanks should be carried out.

4.3.1.3 An overall survey of all ballast tanks and combined cargo/ballast tanks should be carried out. If such survey reveals no visible structural defects, the survey may be limited to a verification that the corrosion prevention system remains effective.

4.3.2 Extent of close-up survey

4.3.2.1 Close-up survey should be carried out to the following extent:

.1 for ballast tanks:

- to the same extent as previous periodical survey, after second periodical survey;

.2 for cargo tanks:

- at least two combined cargo/ballast tanks after second periodical survey. The extent of survey should be based on the record of the previous periodical survey, and repair history of the tanks;
- additionally at least one cargo tank after third periodical survey. The extent of survey should be based on the record of the previous periodical survey and repair history of the tanks.

4.3.2.2 The extent of close-up surveys may be extended as stated in 2.4.3.

4.3.2.3 For areas in tanks where coatings are found to be in GOOD condition as defined in 1.2.9, the extent of close-up survey may be specially considered by the Administration.

4.4 Extent of thickness measurements

4.4.1 Thickness measurements at the intermediate enhanced survey should be carried out for areas found to be suspect as defined in 1.2.6 at the previous periodical survey.

4.4.2 Where substantial corrosion as defined in 1.2.7 is found the extent of thickness measurements should be increased in accordance with the requirements of annex 4.

5 PREPARATIONS FOR SURVEY

5.1 Planning

5.1.1 A specific survey programme should be worked out in advance of the periodical survey by the owner in co-operation with the Administration.

5.1.2 The survey programme should include conditions for survey, access to structures and equipment for surveys, taking into account the requirements of annexes 1, 2 and 3 for close-up survey, thickness measurements and tank pressure testing as described in 2.6.

5.1.3 Alternatively, the close-up survey in this survey programme may be based on a planning document, approved by the Administration, as described in annex 6. The planning document should comply with a procedure for the application of risk assessment developed by the Organization.

5.1.4 The survey programme should take into account the information included in the documentation on board, as described in 6.2 and 6.3.

5.2 Conditions for survey

5.2.1 The owner should provide the necessary facilities for a safe execution of the survey*.

* Reference is made to chapter 10 of the International Safety Guide for Oil Tankers and Terminals (ISGOTT) - Entry into and working in enclosed spaces.

5.2.2 Tanks and spaces should be safe for access, i.e. gas freed, ventilated, etc.

5.2.3 Tanks and spaces should be sufficiently clean and free from water, scale, dirt, oil residues, etc., to reveal significant corrosion, deformation, fractures, damages or other structural deterioration. In particular this applies to areas which are subject to thickness measurement.

5.2.4 Sufficient illumination should be provided to reveal significant corrosion, deformation, fractures, damages or other structural deterioration.

5.3 Access to structures

5.3.1 For overall survey, means should be provided to enable the surveyor to examine the structure in a safe and practical way.

5.3.2 For close-up survey, one or more of the following means for access, acceptable to the surveyor, should be provided:

- permanent staging and passages through structures
- temporary staging and passages through structures
- lifts and moveable platforms
- boats or rafts
- other equivalent means.

5.4 Equipment for survey

5.4.1 Thickness measurement should normally be carried out by means of ultrasonic test equipment. The accuracy of the equipment should be proven to the surveyor as required.

5.4.2 One or more of the following fracture detection procedures may be required if deemed necessary by the surveyor:

- radiographic equipment
- ultrasonic equipment
- magnetic particle equipment
- dye penetrant
- other equivalent means.

5.5 Survey at sea or at anchorage

5.5.1 Survey at sea or at anchorage may be accepted provided the surveyor is given the necessary assistance from the personnel on board. Necessary precautions and procedures for carrying out the survey should be in accordance with 5.1, 5.2, 5.3 and 5.4.

5.5.2 A communication system should be arranged between the survey party in the tank and the responsible officer on deck. This system should also include the personnel in charge of ballast pump handling if boats or rafts are used.

5.5.3 Explosimeter, oxygen-meter, breathing apparatus, lifeline and whistles should be at hand during the survey. When boats or rafts are used, appropriate lifejackets should be available for all participants. Boats or rafts should have satisfactory residual buoyancy and stability even if one chamber is ruptured. A safety check-list should be provided.

5.5.4 Surveys of tanks by means of boats or rafts may only be undertaken with the agreement of the surveyor, who should take into account the safety arrangements provided, including weather forecasting and ship response in reasonable sea conditions.

6 DOCUMENTATION ON BOARD

6.1 General

6.1.1 The owner should supply and maintain on-board documentation as specified in 6.2 and 6.3, which should be readily available for the surveyor. The condition evaluation report referred to in 6.2 should include a translation into English.

6.1.2 The documentation should be kept on board for the lifetime of the ship.

6.2 Survey report file

6.2.1 A survey report file should be a part of the documentation on board consisting of:

- .1 reports of structural surveys (annex 8)
- .2 condition evaluation report (annex 9)
- .3 thickness measurement reports (annex 10)
- .4 survey planning document according to principles in annex 6, where provided.

6.2.2 The survey report file should be available also in the owner's and the Administration offices.

6.3 Supporting documents

6.3.1 The following additional documentation should be available on board:

- .1 main structural plans of cargo and ballast tanks
- .2 previous repair history
- .3 cargo and ballast history
- .4 extent of use of inert gas plant and tank cleaning procedures
- .5 inspections by ship's personnel with reference to:
 - structural deterioration in general;
 - leakages in bulkheads and piping;

- condition of coating or corrosion prevention system, if any,
- a guidance for reporting is shown in annex 5;

and any other information that would help to identify critical structural areas and/or suspect areas requiring inspection.

6.4 Review of documentation on board

6.4.1 Prior to inspection, the surveyor should examine the completeness of the documentation on board, and its contents as a basis for the survey.

7 PROCEDURES FOR THICKNESS MEASUREMENTS

7.1 General

7.1.1 Thickness measurements should normally be carried out under the supervision of the surveyor. However, the surveyor may accept thickness measurements not carried out under his direct supervision provided that:

- .1 the thickness measurements are carried out by a qualified company certified by an organization recognized by the Administration;
- .2 the thickness measurements are carried out within 12 months prior to completion of the periodical survey specified in section 2 or intermediate enhanced survey specified in section 4.

The surveyor should recheck the measurements as deemed necessary to ensure acceptable accuracy.

7.2 Certification of thickness measurement company

7.2.1 The thickness measurements should be carried out by a qualified company certified by an organization recognized by the Administration according to principles stated in annex 7.

7.3 Reporting

7.3.1 A thickness measurement report should be prepared and submitted to the Administration. The report should give the location of measurements, the thickness measured as well as corresponding original thickness. Furthermore, the report should give the date when the measurements were carried out, type of measuring equipment, names of personnel and their qualifications and be signed by the operator. The thickness measurement report should follow the principles as specified in the recommended procedures for thickness measurements set out in annex 10.

7.3.2 The surveyor should verify and countersign the thickness measurement reports.

8 REPORTING AND EVALUATION OF SURVEY

8.1 Evaluation of survey report

8.1.1 The data and information on the structural condition of the ship collected during the survey should be evaluated for acceptability and continued structural integrity of the ship.

8.1.2 The analysis of data should be carried out and endorsed by the Administration and the conclusions of the analysis should form a part of the condition evaluation report.

8.2 Reporting

8.2.1 Principles for survey reporting are shown in annex 8.

8.2.2 A condition evaluation report of the survey and results should be issued to the owner as shown in annex 9 and placed on board the ship for reference at future surveys. The condition evaluation report should be endorsed by the Administration.

ANNEX 1

REQUIREMENTS FOR CLOSE-UP SURVEY AT PERIODICAL SURVEYS

AGE ≤ 5	5 < AGE ≤ 10	10 < AGE ≤ 15	AGE > 15
1	2	3	4
(A) ONE WEB FRAME RING - in a ballast wing tank, if any, or a cargo wing tank used primarily for water ballast	(A) ALL WEB FRAME RINGS - in a ballast wing tank, if any, or a cargo wing tank used primarily for water ballast	(A) ALL WEB FRAME RINGS - in all ballast tanks (A) ALL WEB FRAME RINGS - in a cargo wing tank	As for ships referred to in column 3 Additional transverses included as deemed necessary by the Administration
(B) ONE DECK TRANSVERSE - in a cargo tank	(B) ONE DECK TRANSVERSE - in each of the remaining ballast tanks, if any	(A) ONE WEB FRAME RING - in each remaining cargo wing tank	
(D) ONE TRANSVERSE BULKHEAD - in a ballast tank	(B) ONE DECK TRANSVERSE - in a cargo wing tank	(C) ALL TRANSVERSE BULKHEADS - in all cargo and ballast tanks	
(D) ONE TRANSVERSE BULKHEAD - in a cargo wing tank	(B) ONE DECK TRANSVERSE - in two cargo centre tanks	(E) ONE DECK AND BOTTOM TRANSVERSE - in each cargo centre tank	
(D) ONE TRANSVERSE BULKHEAD - in a cargo centre tank	(C) BOTH TRANSVERSE BULKHEADS in a wing ballast tank, if any, or a cargo wing tank used primarily for water ballast	(F) As considered necessary by the Administration	
	(D) ONE TRANSVERSE BULKHEAD - in each remaining ballast tank		
	(D) ONE TRANSVERSE BULKHEAD - in a cargo wing tank		
	(D) ONE TRANSVERSE BULKHEAD - in two cargo centre tanks		

- (A) Complete transverse web frame ring including adjacent structural members
- (B) Deck transverse including adjacent deck structural members
- (C) Transverse bulkhead complete - including girder system and adjacent members
- (D) Transverse bulkhead lower part - including girder system and adjacent structural members
- (E) Deck and bottom transverse including adjacent structural members
- (F) Additional complete transverse web frame ring

ANNEX 2

REQUIREMENTS FOR THICKNESS MEASUREMENTS AT PERIODICAL SURVEYS

AGE \leq 5	5 < AGE \leq 10	10 < AGE \leq 15	AGE > 15
1	2	3	4
<p>1. One section of deck plating for the full beam of the ship within the cargo area (in way of a ballast tank, if any, or a cargo tank used primarily for water ballast)</p> <p>2. Measurements of structural members subject to close-up survey according to annex 1, for general assessment and recording of corrosion pattern</p> <p>3. Suspect areas</p>	<p>1. Within the cargo area:</p> <p>.1 Each deck plate</p> <p>.2 One transverse section</p> <p>2. Measurements of structural members subject to close-up survey according to annex 1, for general assessment and recording of corrosion pattern</p> <p>3. Suspect areas</p> <p>4. Selected wind and water strakes outside the cargo area</p>	<p>1. Within the cargo area:</p> <p>.1 Each deck plate</p> <p>.2 Two transverse sections</p> <p>2. Measurements of structural members subject to close-up survey according to annex 1, for general assessment and recording of corrosion pattern</p> <p>3. Suspect areas</p> <p>4. Selected wind and water strakes outside the cargo area</p> <p>5. All wind and water strakes within the cargo area</p>	<p>1. Within the cargo area:</p> <p>.1 Each deck plate</p> <p>.2 Three transverse sections</p> <p>.3 Each bottom plate</p> <p>2. Measurements of structural members subject to close-up survey according to annex 1, for general assessment and recording of corrosion pattern</p> <p>3. Suspect areas</p> <p>4. Selected wind and water strakes outside the cargo area</p> <p>5. All wind and water strakes within the cargo area</p>

ANNEX 3

REQUIREMENTS FOR TANK PRESSURE TESTING AT PERIODICAL SURVEYS

AGE \leq 5	5 < AGE \leq 10	10 < AGE \leq 15	AGE > 15
<p>1. Cargo tank boundaries facing ballast tanks, void spaces, pipe tunnels, fuel oil tanks, pump-rooms or cofferdams.</p> <p>2. Representative tanks for fresh water, fuel oil and lubrication oil.</p>	<p>1. Cargo tank boundaries facing ballast tanks, void spaces, pipe tunnels, fuel oil tanks, pump-rooms or cofferdams.</p> <p>2. All cargo tank bulkheads which form the boundaries of segregated cargoes.</p> <p>3. Representative tanks for fresh water, fuel oil and lubrication oil.</p>	<p>1. Cargo tank boundaries facing ballast tanks, void spaces, pipe tunnels, fuel oil tanks, pump-rooms or cofferdams.</p> <p>2. All remaining cargo tank bulkheads.</p> <p>3. Representative tanks for fresh water, fuel oil and lubrication oil.</p>	<p>1. Cargo tank boundaries facing ballast tanks, void spaces, pipe tunnels, fuel oil tanks, pump-rooms or cofferdams.</p> <p>2. All remaining cargo tank bulkheads.</p> <p>3. All fresh water fuel oil and lubrication oil tanks.</p>

ANNEX 4

REQUIREMENTS FOR EXTENT OF THICKNESS MEASUREMENTS AT AREAS
 OF SUBSTANTIAL CORROSION. PERIODICAL SURVEY
 WITHIN THE CARGO AREA

Bottom structure

STRUCTURAL MEMBER	EXTENT OF MEASUREMENT	PATTERN OF MEASUREMENT
1. Bottom plating	Minimum of 3 bays across tank, including aft bay. Measurements around and under all bell mouths.	5 point pattern for each panel between longitudinals and webs.
2. Bottom longitudinals	Minimum of 3 longitudinals in each bay where bottom plating measured.	3 measurements in line across flange and 3 measurements on vertical web.
3. Bottom girders and brackets	At fore and aft transverse bulkhead bracket toes and in centre of tanks.	Vertical line of single measurements on web plating with one measurement between each panel stiffener, or a minimum of three measurements. Two measurements across face flat. 5 point pattern on girder/bulkhead brackets.
4. Bottom transverse webs	3 webs in bays where bottom plating measured, with measurements at both ends and middle.	5 point pattern over 2 square metre area. Single measurements on face flat.
5. Panel stiffening	Where fitted.	Single measurements.

Deck structure

STRUCTURAL MEMBER	EXTENT OF MEASUREMENT	PATTERN OF MEASUREMENT
1. Deck plating	Two bands across tank.	Minimum of three measurements per plate per band.
2. Deck longitudinals	Minimum of 3 longitudinals in each of two bays.	3 measurements in line vertically on webs, and 2 measurements on flange (if fitted).
3. Deck girders and brackets	At fore and aft transverse bulkhead, bracket toes and in centre of tanks.	Vertical line of single measurements on web plating with one measurement between each panel stiffener, or a minimum of three measurements. Two measurements across face flat. 5 point pattern on girder/bulkhead brackets.
4. Deck transverse webs	Minimum of two webs with measurements at middle and both ends of span.	5 point pattern over about 2 square metre area. Single measurements on face flat.
5. Panel stiffening	Where available.	Single measurements.

Shell and longitudinal bulkheads

STRUCTURAL MEMBER	EXTENT OF MEASUREMENT	PATTERN OF MEASUREMENT
1. Deckhead and bottom strakes, and strakes in way of stringer platforms	Plating between each pair of longitudinals in a minimum of 3 bays	Single measurement
2. All other strakes	Plating between every third pair of longitudinals in same 3 bays	Single measurement
3. Longitudinals - deckhead and bottom strakes	Each longitudinal in same 3 bays	3 measurements across web and 1 measurement on flange
4. Longitudinals - all others	Every third longitudinal in same 3 bays	3 measurements across web and 1 measurement on flange
5. Longitudinals - bracket	Minimum of three at top, middle and bottom of tank in same 3 bays	5 point pattern over area of bracket
6. Web frames and cross ties	3 webs with minimum of three locations on each web, including in way of cross tie connections	5 point pattern over about 2 square metre area, plus single measurements on web frame and cross tie face flats

Transverse bulkheads and swash bulkheads

STRUCTURAL MEMBER	EXTENT OF MEASUREMENT	PATTERN OF MEASUREMENT
1. Deckhead and bottom strakes, and strakes in way of stringer platforms	Plating between pair of stiffeners at three locations - approx. 1/4, 1/2 and 3/4 width of tank	5 points pattern between stiffeners over 1 metre length
2. All other strakes	Plating between pair of stiffeners at middle location	Single measurement
3. Strakes in corrugated bulkheads	Plating for each change of scantling at centre of panel and at flange or fabricated connection	5 point pattern over about 1 square metre of plating
4. Stiffeners	Minimum of three typical stiffeners	For web, 5 point pattern over span between bracket connections (2 measurements across web at each bracket connection, and one at centre of span). For flange, single measurements at each bracket toe and at centre of span
5. Brackets	Minimum of three at top, middle and bottom of tank	5 point pattern over area of bracket
6. Deep webs and girders	Measurements at toe of bracket and centre of span	For web, 5 point pattern over about 1 square metre area. 3 measurements across face flat
7. Stringer platforms	All stringers with measurements at both ends and middle	5 point pattern over 1 square metre area plus single measurements near bracket toes and on face flats

ANNEX 5

OWNER'S INSPECTION REPORT

Structural condition

Ship's name:							
OWNERS'S INSPECTION REPORT - Structural condition For tank No.:							
Grade of steel:	Deck	:.....	Side	:.....			
	Bottom	:.....	Longitudinal bulkhead	:.....			
Elements	Cracks	Buckles	Corrosion	Coating condition	Pitting	Modification/ repair	Other
Deck:							
Bottom:							
Side:							
Longitudinal bulkheads:							
Transverse bulkheads:							
Repairs carried out due to:							
Thickness measurements carried out (dates):							
Results in general:							
Overdue surveys:							
Outstanding conditions of class:							
Comments:							
Date of inspection:							
Inspected by:							
Signature:							

ANNEX 6

PRINCIPLES FOR PLANNING DOCUMENT

1 A planning document is intended to identify critical structural areas and to stipulate the minimum extent, locations and means for close-up survey and thickness measurements with respect to sections and internal structures as well as nominate suspect areas.

2 The document should be worked out by the owner in co-operation with the Administration well in advance of the survey.

3 The basis for nomination of tanks and areas referred to in 1 is a risk assessment in consideration of possible deteriorations where the following elements on the particular ship are taken into account:

- .1 design features such as extent of high tensile steel and local details;
- .2 former history available at owner's and Administration offices with respect to corrosion, cracking, buckling, indents and repairs for the particular ship as well as similar ships;
- .3 information from same offices with respect to type of cargo, use of different tanks for cargo/ballast, corrosion prevention system and condition of coating, if any.

4 The degree of criticality should be judged and decided on the basis of recognized principles and practice.

5 The planning document should contain:

- .1 main particulars;
- .2 plan of tanks;
- .3 list of tanks with information on use, protection and condition of coating;
- .4 corrosion risk nomination of tanks;
- .5 design risk nomination of structures;
- .6 nomination of tanks and areas for close-up survey;
- .7 nomination of sections and structures for thickness measurements; and
- .8 list of acceptable corrosion allowance of different structures.

ANNEX 7

PROCEDURES FOR CERTIFICATION OF A COMPANY ENGAGED IN THICKNESS MEASUREMENT OF HULL STRUCTURES

1 Application

This guidance applies for certification of the company which intends to engage in the thickness measurement of hull structures of ships.

2 Procedures for certification

Submission of documents

2.1 The following documents should be submitted to an organization recognized by the Administration for approval.

- .1 Outline of the company, e.g. organization and management structure.
- .2 Experience of the company on thickness measurement of hull structures of ships.
- .3 Technicians careers, i.e. experience of technicians as thickness measurement operators, technical knowledge and experience of hull structure, etc. Operators should be qualified according to a recognized industrial NDT Standard.
- .4 Equipment used for thickness measurement such as ultrasonic testing machines and their maintenance/calibration procedures.
- .5 A guide for thickness measurement operators.
- .6 Training programmes for technicians for thickness measurement.
- .7 Measurement record format in accordance with recommended procedures for thickness measurements (see annex 10).

Auditing of the company

2.2 Upon reviewing the documents submitted with satisfactory results, the company should be audited in order to ascertain that the company is duly organized and managed in accordance with the documents submitted, and eventually is capable of conducting thickness measurement of the hull structure of ships.

2.3 Certification is conditional upon an on-board demonstration of thickness measurement as well as satisfactory reporting.

3 Certification

3.1 Upon satisfactory results of both the audit of the company referred to in 2.2 and the demonstration tests referred to in 2.3, the Administration or organization recognized by the Administration should issue a Certificate of Approval as well as a notice to the effect that the thickness measurement operation system of the company has been certified.

3.2 Renewal/endorsement of the certificate should be made at intervals not exceeding 3 years by verification that original conditions are maintained.

4 Report of any alteration to the certified thickness measurement operation system

In case where any alteration to the certified thickness measurement operation system of the company is made, such an alteration should be immediately reported to the organization recognized by the Administration. Re-audit should be made where deemed necessary by the organization recognized by the Administration.

5 Withdrawal of the certification

The certification may be withdrawn in the following cases:

- .1 where the measurements were improperly carried out or the results were improperly reported;
- .2 where the surveyor found any deficiencies in the approved thickness measurement operation system of the company;
- .3 where the company failed to report any alteration referred to in 4 to the organization recognized by the Administration as required.

ANNEX 8

REPORTING PRINCIPLES

Reporting formats should be worked out individually by the Administration. As a principle the following contents of reports for oil tanker structures should be included as applicable for the survey.

- 1 Type of survey (periodical survey, intermediate enhanced survey, annual survey, other)
 - 1.1 Date, location, whether or not the survey was in dry-dock and whether or not the survey was completed.
 - 1.2 Date of the previous:
 - bottom inspection
 - dry-docking
- 2 Extent of the survey
 - 2.1 Identification of overall surveyed tanks.
 - 2.2 Where in each tank close-up survey has been carried out, and means of access.
 - 2.3 Identification of tanks and location of structures to be given with respect to the thickness measurements carried out.
 - 2.4 Identification of pressure tested tanks.
- 3 Results of the survey
 - 3.1 Coating condition of each tank (if applicable). Identification of tanks with anodes.
 - 3.2 Structural condition of each tank:
 - identified tank found in satisfactory condition. Otherwise identification of findings which should be corrected or recorded, such as:
 - corrosion: - structure members
 - type of corrosion (pitting, general)
 - extent
 - cracks (location)
 - buckling (location)
 - indents (location)

The narrative report may be supplemented by sketches/photos of damages/repairs.

- 3.3 Thickness measurement report endorsed by the attending surveyor.
- 4 Actions to possible findings
- 4.1 Repair in identified tanks:
- structural member
 - repair method
 - repair extent
- 4.2 Recorded findings considered not to necessitate immediate repairs. Memoranda for future inspections and thickness measurements should be given, e.g. for areas found as suspect with respect to corrosion (see 1.2.6).
- 4.3 Condition of class/flag State requirements.

The structure of the reporting contents may be different, depending on the report system for the Administration.

ANNEX 9

CONDITION EVALUATION REPORT
 Issued upon completion of periodical survey

General particulars

Ship's name: Class/Administration identity number:
 Previous class/Administration identity
 number(s):
 IMO number:

Port of registry: National flag:
 Previous national flag(s):

Deadweight (metric tonnes): Gross tonnage:
 National:
 ITC (69):

Date of build: Classification notation:

Date of major conversion:

Type of conversion: Owner:
 Previous owner(s):

1 The survey reports and documents listed below have been reviewed by the undersigned and found to be satisfactory

2 The periodical survey has been completed in accordance with the present guidelines on (date)

Condition evaluation report completed by	Name Signature	Title
Office	Date	
Condition evaluation report verified by	Name Signature	Title
Office	Date	

Attached reports and documents:

- 1)
- 2)
- 3)
- 4)
- 5)
- 6)

Contents of condition evaluation report

- Part 1 - General particulars: - See front page
- Part 2 - Report review: - Where and how survey was done
- Part 3 - Close-up survey: - Extent (which tanks)
- Part 4 - Thickness measurements: - Reference to thickness measurement report
 - Summary of where measured
 - Separate form indicating the tanks/areas with substantial corrosion, and corresponding:
 - thickness diminution
 - corrosion pattern
- Part 5 - Tank corrosion prevention system: - Separate form indicating:
 - location of coating/anodes
 - condition of coating (if applicable)
- Part 6 - Repairs: - Identification of tanks/areas
- Part 7 - Condition of class/flag State requirements:
- Part 8 - Memoranda: - Acceptable defects
 - Any points of attention for future surveys, e.g. for suspect areas
 - Extended annual/intermediate enhanced survey due to coating breakdown
- Part 9 - Conclusion: - Statement on evaluation/verification of survey report

Extract of thickness measurements

Reference is made to the thickness measurements report:

Position of substantially corroded tanks/areas ^{1/}	Thickness diminution [%]	Corrosion pattern ^{2/}	Remarks: e.g. Ref. attached sketches

Remarks

^{1/} Substantial corrosion, i.e. 75%-100% of acceptable margins wasted.

^{2/} P = Pitting
C = Corrosion in general

Tank corrosion prevention system

Tank Nos. ^{1/}	Tank corrosion prevention system ^{2/}	Coating condition ^{3/}	Remarks

Remarks

1/ All segregated ballast tanks and combined cargo/ballast tanks should be listed.

2/ C = Coating A = Anodes NP = No protection

3/ Coating condition according to the following standard.

GOOD condition with only minor spot rusting.

FAIR condition with local breakdown of coating at edges of stiffeners and weld connections and/or light rusting over 20% or more of areas under consideration, but less than as defined for POOR condition.

POOR condition with general breakdown of coating over 20% or more of areas or hard scale at 10% or more of areas under consideration.

If coating condition "POOR" is given, extended annual surveys should be introduced. This should be noted in part 7 of the Contents of condition evaluation report.

ANNEX 10

RECOMMENDED PROCEDURES FOR THICKNESS MEASUREMENTS

General

- 1 These procedures should be used for recording thickness measurements as required by annexes 2 and 4.
- 2 Reporting forms TM1, TM2-T, TM3-T, TM4-T, TM5-T and TM6-T, set out in appendix 2, should be used for recording thickness measurements.
- 3 Appendix 3 contains guidance diagrams and notes relating to the reporting forms and the requirements for thickness measurement.
- 4 The reporting forms should, where appropriate, be supplemented by data presented on structural sketches.

- Appendix 1 General particulars
- Appendix 2 Reports on thickness measurement
- Appendix 3 Guidance on thickness measurement

APPENDIX 1

GENERAL PARTICULARS

Ship's name:

IMO number:

Class/Administration identity number:

Port of registry:

Gross tonnage:

Deadweight:

Date of build:

Classification society:

Name of company performing thickness measurement:

Thickness measurement company certified by:

Certificate number:

Certificate valid from:.....,..... to

Place of measurement:

First date of measurement:

Last date of measurement:

Periodical survey/intermediate enhanced survey due*:

Details of measurement equipment:

Qualification of operator:

Report number: _____ consisting of pages

Name of operator: Name of surveyor:

Signature of operator: Signature of surveyor:

Company official stamp: Administration:
Official stamp:

* Delete as appropriate

APPENDIX 2
REPORTS ON THICKNESS MEASUREMENT
Report on thickness measurement of all deck plating, all bottom shell plating or side shell plating (TM1-T)

Ship's name IMO number Class identity No. Report No.

STRAKE POSITION	PLATE POSITION	No or Letter	Org. Thk. mm	Forward Reading								Aft Reading						Mean diminution	
				Gauged		Diminution P		Diminution S		Gauged		Diminution P		Diminution S		P	S		
				P	S	mm	%	mm	%	P	S	mm	%	mm	%				
12th forward																			
11th																			
10th																			
9th																			
8th																			
7th																			
6th																			
5th																			
4th																			
3rd																			
2nd																			
1st																			
Amidships																			
1st aft																			
2nd																			
3rd																			
4th																			
5th																			
6th																			
7th																			
8th																			
9th																			
10th																			
11th																			
12th																			

Operator's signature

Surveyor's signature

NOTES - See reverse

NOTES

- 1 This report should be used for recording the thickness measurement of:
 - 1.1 All strength deck plating within the cargo area.
 - 1.2 All keel, bottom shell plating and bilge plating within the cargo area.
 - 1.3 Side shell plating including selected wind and water strakes outside the cargo area.
- 2 The strake position should be clearly indicated as follows:
 - 2.1 For strength deck indicate the number of the strake of plating inboard from the stringer plate.
 - 2.2 For bottom plating indicate the number of the strake of plating outboard from the keel plate.
 - 2.3 For side shell plating give number of the strake of plating below sheerstrake and letter as shown on shell expansion.
- 3 For oil tankers all deck plating strakes should be recorded, for ore/oil ships only the deck plating strakes outside line of openings should be recorded.
- 4 Measurements should be taken at the forward and aft areas of all plates and where plates cross ballast/cargo tank boundaries separate measurements for the area of plating in way of each type of tank should be recorded.
- 5 The single measurements recorded should represent the average of multiple measurements.

Report on thickness measurement of shell and deck plating (one, two or three transverse sections) (TM2-T(1))

Ship's name IMO number Class identity No. Report No.

STRENGTH DECK AND SHEERSTRAKE PLATING																								
STRAKE POSITION	FIRST TRANSVERSE SECTION AT FRAME NUMBER								SECOND TRANSVERSE SECTION AT FRAME NUMBER								THIRD TRANSVERSE SECTION AT FRAME NUMBER							
	No. or Letter	Org. Thk.	Gauged		Diminution P		Diminution S		No. or Letter	Org. Thk.	Gauged		Diminution P		Diminution S		No. or Letter	Org. Thk.	Gauged		Diminution P		Diminution S	
			P	S	mm	%	mm	%			P	S	mm	%	mm	%			P	S	mm	%	mm	%
Stringer plate																								
1st strake inboard																								
2nd																								
3rd																								
4th																								
5th																								
6th																								
7th																								
8th																								
9th																								
10th																								
11th																								
12th																								
13th																								
14th																								
centre strake																								
sheer strake																								
TOPSIDE TOTAL																								

Operator's signature

Surveyor's signature

NOTES - See reverse

NOTES

1 This report should be used for recording the thickness measurement of strength deck plating and sheerstrake plating transverse sections:

One, two or three sections within the cargo area comprising of the structural items (1), (2) and (3) as shown on the diagrams of typical transverse section indicating longitudinal and transverse members, in appendix 3.

2 For oil tankers all deck plating strakes should be recorded, for ore/oil ships only the deck plating strakes outside line of openings should be recorded.

3 The topside area comprises deck plating, stringer plate and sheerstrake (including rounded gunwales).

4 The exact frame station of measurement should be stated.

5 The single measurements recorded should represent the average of multiple measurements.

Report on thickness measurement of shell and deck plating (one, two or three transverse sections) (TM2-T(2))

Ship's name IMO number Class identity No. Report No.

SHELL PLATING																									
STRAKE POSITION	FIRST TRANSVERSE SECTION AT FRAME NUMBER								SECOND TRANSVERSE SECTION AT FRAME NUMBER						THIRD TRANSVERSE SECTION AT FRAME NUMBER										
	No. or Letter	Org. Thk.	Gauged		Diminution P		Diminution S		No. or Letter	Org. Thk.	Gauged		Diminution P		Diminution S		No. or Letter	Org. Thk.	Gauged		Diminution P		Diminution S		
			P	S	mm	%	mm	%			P	S	mm	%	mm	%			P	S	mm	%	mm	%	
1st below shear strake																									
2nd																									
3rd																									
4th																									
5th																									
6th																									
7th																									
8th																									
9th																									
10th																									
11th																									
12th																									
13th																									
14th																									
15th																									
16th																									
17th																									
18th																									
19th																									
20th																									
keel strake																									
BOTTOM TOTAL																									

Operator's signature

Surveyor's signature

NOTES - See reverse

NOTES

1 This report should be used for recording the thickness measurements of shell plating transverse sections:

One, two or three sections within the cargo area comprising of the structural items (4), (5), (6), and (7) as shown on the diagrams of typical transverse section indicating longitudinal and transverse members, in appendix 3.

2 The bottom area comprises keel, bottom and bilge plating.

3 The exact frame station of measurement should be stated.

4 The single measurements recorded should represent the average of multiple measurements.

NOTES

1 This report should be used for recording the thickness measurement of longitudinal members at transverse sections:

One, two or three sections within the cargo area comprising of the structural items (8) to (20) as shown on the diagrams of typical transverse section indicating longitudinal and transverse members, in appendix 3.

2 The exact frame station of measurement should be stated.

3 The single measurements recorded should represent the average of multiple measurements.

NOTES

1 This report should be used for recording the thickness measurement of transverse structural members, comprising of the appropriate structural items (25) to (32) as shown on the diagrams of typical transverse section indicating longitudinal and transverse members, in appendix 3.

2 Guidance for areas of measurement is indicated in tables 1 to 3 of appendix 3.

3 The single measurements recorded should represent the average of multiple measurements.

**Report on thickness measurement of W.T./O.T. transverse bulkheads
 within the cargo tank or cargo hold spaces (TM 5 - T)**

Ship's name IMO number Class identity No. Report No.

TANK/HOLD DESCRIPTION :						FRAME No. :	
LOCATION OF STRUCTURE :							
STRUCTURAL COMPONENT (PLATING/STIFFENER)	Original Thickness mm	Gauged		Diminution P		Diminution S	
		Port	Starboard	mm	%	mm	%

Operator's signature

Surveyor's signature

NOTES - See reverse

NOTES

1 This report should be used for recording the thickness measurement of W.T./O.T. transverse bulkheads.

2 Guidance for areas of measurement is indicated in tables 1 to 3 of appendix 3.

3 The single measurements recorded should represent the average of multiple measurements.

Report on thickness measurement of miscellaneous structural members (TM6-T)

Ship's name IMO number Class identity No. Report No.

STRUCTURAL MEMBER :							SKETCH			
LOCATION OF STRUCTURE :										
Description	Org. Thk.	Gauged		Diminution P		Diminution S				
		P	S	mm	%	mm	%			

Operator's signature

Surveyor's signature

Notes - See reverse

NOTES

1 This report should be used for recording the thickness measurement of miscellaneous structural members including the structural items (36), (37) and (38) shown in appendix 3.

2 The single measurements recorded should represent the average of multiple measurements.

APPENDIX 3

GUIDANCE OF THICKNESS MEASUREMENT

Typical transverse section of oil tanker indicating longitudinal and transverse members

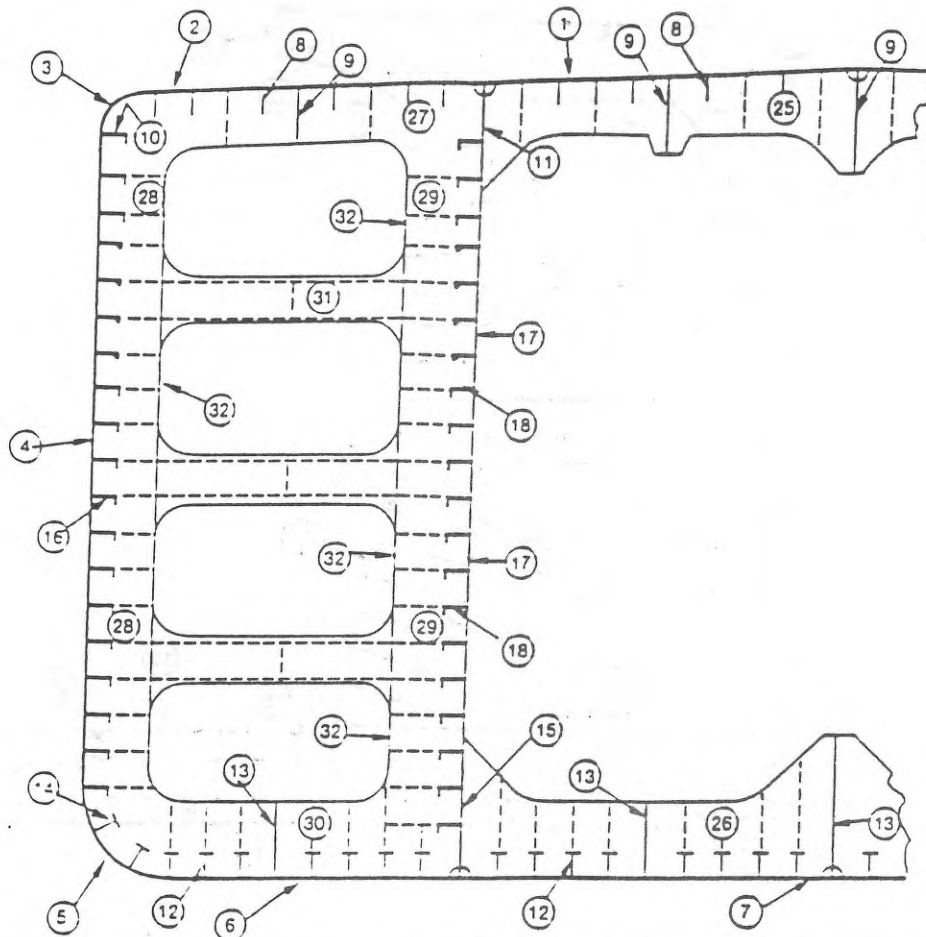

Report on TM2-T (1)&(2)	
1	Strength deck plating
2	Stringer plate
3	Sheerstrake
4	Side shell plating
5	Bilge plating
6	Bottom shell plating
7	Keel plate

Report on TM6-T	
36	Hatch coamings
37	Deck plating between hatches
39	Hatch covers
42	

Report on TM3-T	
8	Deck longitudinals
9	Deck girders
10	Sheerstrake longitudinals
11	Longitudinal bulkhead top strake
12	Bottom longitudinals
13	Bottom girders
14	Bilge longitudinals
15	Longitudinal bulkhead lower strake
16	Side shell longitudinals
17	Longitudinal bulkhead plating (remainder)
18	Longitudinal bulkhead longitudinals
19	Inner bottom plating
20	Inner bottom longitudinals
21	
22	
23	
24	

Report on TM4-T	
25	Deck transverse centre tank
26	Bottom transverse centre tank
27	Deck transverse wing tank
28	Side shell vertical web
29	Longitudinal bulkhead vertical web
30	Bottom transverse wing tank
31	Struts
32	Transverse web face plate
33	D.B. Floors
34	
35	

Typical transverse section of ore/oil ship indicating longitudinal and transverse members

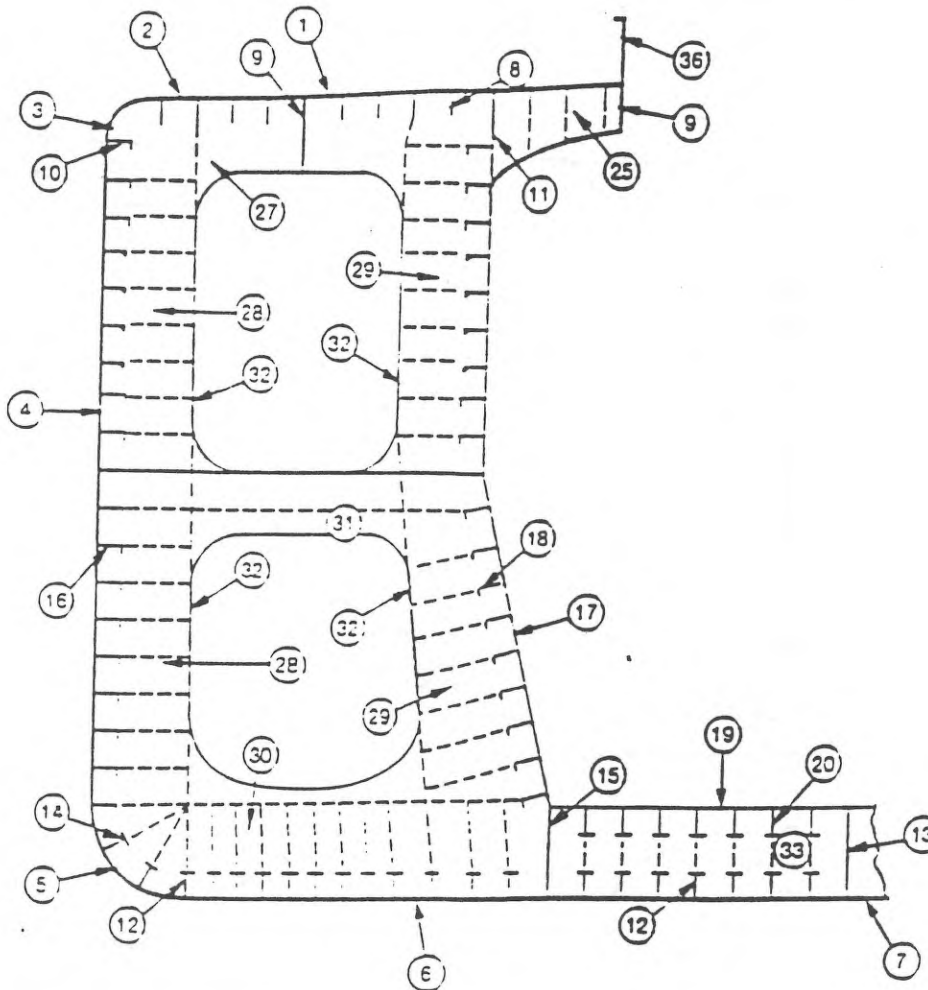

Report on TM2-T (1)&(2)	
(1)	Strength deck plating
(2)	Stringer plate
(3)	Sheerstrake
(4)	Side shell plating
(5)	Side plating
(6)	Bottom shell plating
(7)	Keel plate

Report on TM3-T	
(8)	Deck longitudinals
(9)	Deck girders
(10)	Sheerstrake longitudinals
(11)	Longitudinal bulkhead top strake
(12)	Bottom longitudinals
(13)	Bottom girders
(14)	Bilge longitudinals
(15)	Longitudinal bulkhead lower strake
(16)	Side shell longitudinals
(17)	Longitudinal bulkhead plating (remainder)
(18)	Longitudinal bulkhead longitudinals
(19)	Inner bottom plating
(20)	Inner bottom longitudinals
(21)	
(22)	
(23)	
(24)	

Report on TM4-T	
(25)	Deck transverse centre tank
(26)	Bottom transverse centre tank
(27)	Deck transverse wing tank
(28)	Side shell vertical web
(29)	Longitudinal bulkhead vertical web
(30)	Bottom transverse wing tank
(31)	Struts
(32)	Transverse web face plate
(33)	D.B. Floors
(34)	
(35)	

Report on TM6-T	
(36)	Hatch coamings
(37)	Deck plating between hatches
(38)	Hatch covers
(39)	
(40)	

Transverse section outline

(To be used for longitudinal and transverse members where typical oil tanker or oil/ore ship sections are not applicable)

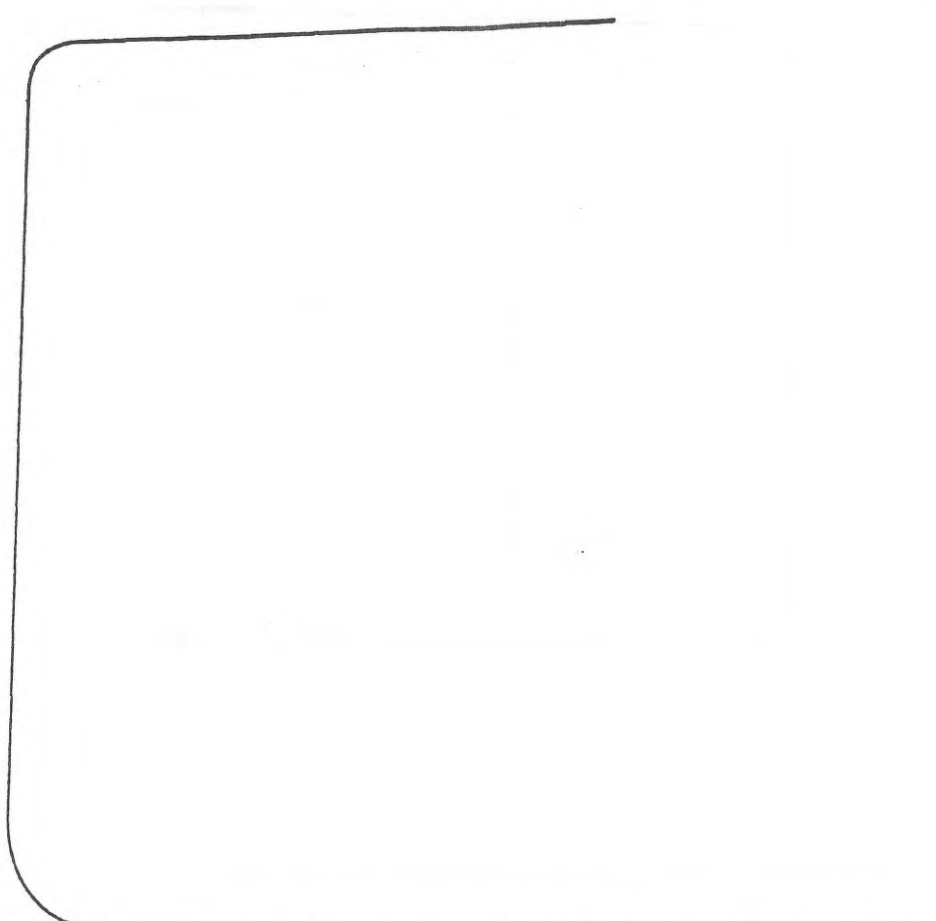

Report on TM2-T (1)&(2)	
1	Strength deck plating
2	Stringer plate
3	Sheerstrake
4	Side shell plating
5	Bilge plating
6	Bottom shell plating
7	Keel plate

Report on TM6-T	
36	Hatch coamings
37	Deck plating between hatches
38	Hatch covers
39	
40	

Report on TM3-T	
8	Deck longitudinals
9	Deck girders
10	Sheerstrake longitudinals
11	Longitudinal bulkhead top strake
12	Bottom longitudinals
13	Bottom girders
14	Bilge longitudinals
15	Longitudinal bulkhead lower strake
16	Side shell longitudinals
17	Longitudinal bulkhead plating (remainder)
18	Longitudinal bulkhead longitudinals
19	Inner bottom plating
20	Inner bottom longitudinals
21	
22	
23	
24	

Report on TM4-T	
25	Deck transverse centre tank
26	Bottom transverse centre tank
27	Deck transverse wing tank
28	Side shell vertical web
29	Longitudinal bulkhead vertical web
30	Bottom transverse wing tank
31	Struts
32	Transverse web face plate
33	D.B. Floors
34	
35	

Typical transverse sections
showing all longitudinal members to be reported on TM2-T and TM3-T

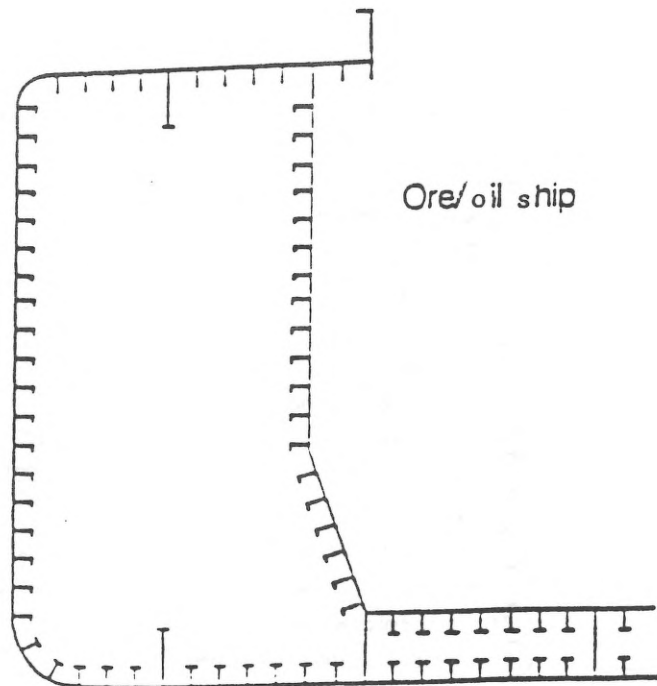
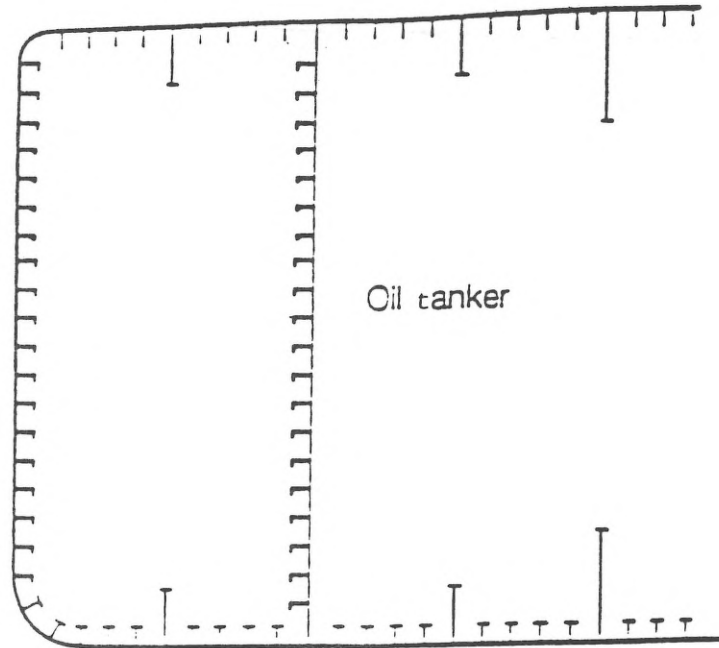

Thickness measurement requirements

Table 1

AGE ≤ 5	5 < AGE ≤ 10	10 < AGE ≤ 15	AGE > 15
<p>1. One section of deck plating for the full beam of the ship within the cargo area (in way of a ballast tank, if any, or a cargo tank used primarily for water ballast)</p> <p>2. Measurements of structural members subject to close-up survey according to tables 2 and 3 of this appendix, for general assessment and recording of corrosion pattern</p> <p>3. Suspect areas</p>	<p>1. Within the cargo area:</p> <p>.1 Each deck plate</p> <p>.2 One transverse section</p> <p>2. Measurements of structural members subject to close-up survey according to tables 2 and 3 of this appendix, for general assessment and recording of corrosion pattern</p> <p>3. Suspect areas</p> <p>4. Selected wind and water strakes outside the cargo area</p>	<p>1. Within the cargo area:</p> <p>.1 Each deck plate</p> <p>.2 Two transverse sections</p> <p>2. Measurements of structural members subject to close-up survey according to tables 2 and 3 of this appendix, for general assessment and recording of corrosion pattern</p> <p>3. Suspect areas</p> <p>4. Selected wind and water strakes outside the cargo area</p> <p>5. All wind and water strakes within the cargo area</p>	<p>1. Within the cargo area:</p> <p>.1 Each deck plate</p> <p>.2 Three transverse sections</p> <p>.3 Each bottom plate</p> <p>2. Measurements of structural members subject to close-up survey according to tables 2 and 3 of this appendix, for general assessment and recording of corrosion pattern</p> <p>3. Suspect areas</p> <p>4. Selected wind and water strakes outside the cargo area</p> <p>5. All wind and water strakes within the cargo area</p>

Close-up survey requirements

Table 2

AGE ≤ 5	5 < AGE ≤ 10	10 < AGE ≤ 15	AGE > 15
1	2	3	4
(A) ONE WEB FRAME RING - in a ballast wing tank, if any, or a cargo wing tank used primarily for water ballast	(A) ALL WEB FRAME RINGS - in a ballast wing tank, if any, or a cargo wing tank used primarily for water ballast	(A) ALL WEB FRAME RINGS - in all ballast tanks (A) ALL WEB FRAME RINGS - in a cargo wing tank (A) ONE WEB FRAME RING - in each remaining cargo wing tank	As for ships referred to in column 3 Additional transverses included as deemed necessary by the Administration
(B) ONE DECK TRANSVERSE - in a cargo tank	(B) ONE DECK TRANSVERSE - in each of the remaining ballast tanks, if any	(C) ALL TRANSVERSE BULKHEADS - in all cargo and ballast tanks	
(D) ONE TRANSVERSE BULKHEAD - in a ballast tank	(B) ONE DECK TRANSVERSE - in a cargo wing tank	(E) ONE DECK AND BOTTOM TRANSVERSE - in each cargo centre tank	
(D) ONE TRANSVERSE BULKHEAD - in a cargo wing tank	(B) ONE DECK TRANSVERSE - in two cargo centre tanks	(F) As considered necessary by the Administration	
(D) ONE TRANSVERSE BULKHEAD - in a cargo centre tank	(C) BOTH TRANSVERSE BULKHEADS in a wing ballast tank, if any, or a cargo wing tank used primarily for water ballast		
	(D) ONE TRANSVERSE BULKHEAD - in each remaining ballast tank		
	(D) ONE TRANSVERSE BULKHEAD - in a cargo wing tank		
	(D) ONE TRANSVERSE BULKHEAD - in two cargo centre tanks		

- (A) Complete transverse web frame ring including adjacent structural members
- (B) Deck transverse including adjacent deck structural members
- (C) Transverse bulkhead complete - including girder system and adjacent members
- (D) Transverse bulkhead lower part - including girder system and adjacent structural members
- (E) Deck and bottom transverse including adjacent structural members*
- (F) Additional complete transverse web frame ring

NOTE: * For ore/oil ships applies to deck transverse only

Table 3

Close-up survey requirements

(Transverse sections of oil tankers and ore/oil ships showing typical areas for thickness measurement in association with close-up survey requirements)

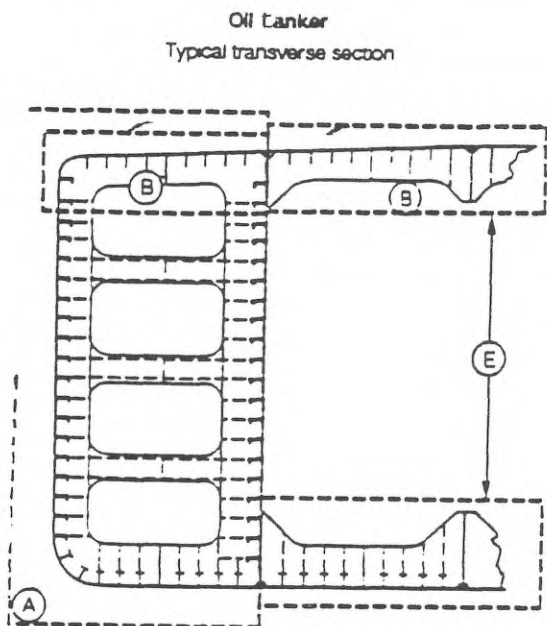

Thickness to be reported on
TM3-T and TM4-T as appropriate

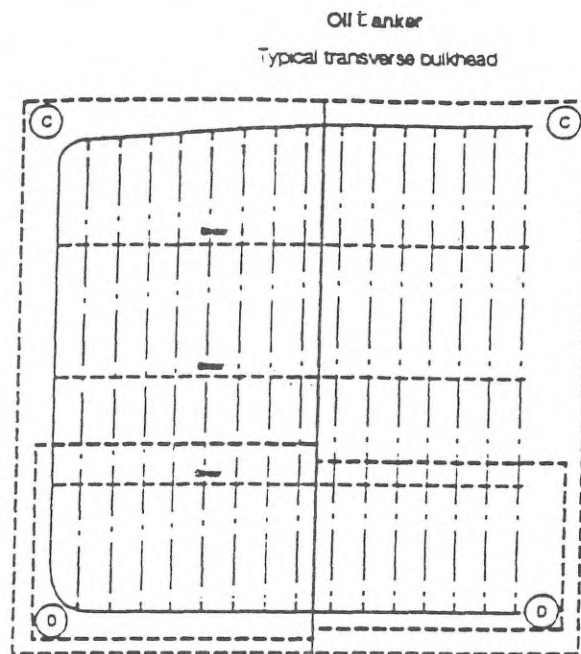

Thickness to be reported on TM5-T

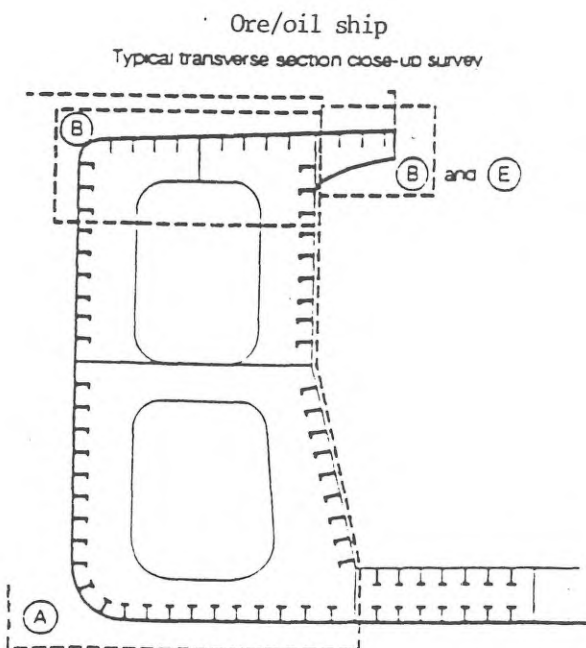

Thickness to be reported on
TM3-T and TM4-T as appropriate

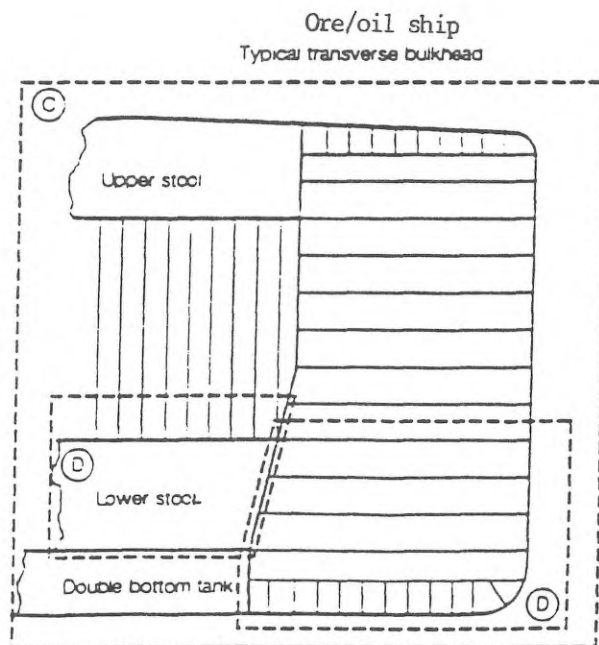

Thickness to be reported on TM5-T

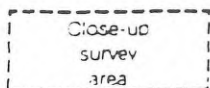

Recommendations for the extent and pattern of thickness measurements are indicated in annex 4.

